

Circuitor

Power analyzer

CVM-E3-MINI



INSTRUCTION MANUAL

(M170B01-03-24A)





SAFETY PRECAUTIONS

Follow the warnings described in this manual with the symbols shown below.



DANGER

Warns of a risk, which could result in personal injury or material damage.



ATTENTION

Indicates that special attention should be paid to a specific point.

If you must handle the unit for its installation, start-up or maintenance, the following should be taken into consideration:



Incorrect handling or installation of the device may result in injury to personnel as well as damage to the device. In particular, handling with voltages applied may result in electric shock, which may cause death or serious injury to personnel. Defective installation or maintenance may also lead to the risk of fire.

Read the manual carefully prior to connecting the device. Follow all installation and maintenance instructions throughout the device's working life. Pay special attention to the installation standards of the National Electrical Code.



Refer to the instruction manual before using the device

In this manual, if the instructions marked with this symbol are not respected or carried out correctly, it can result in injury or damage to the device and /or installations.

CIRCUTOR S.A.U. reserves the right to modify features or the product manual without prior notification.

DISCLAIMER

CIRCUTOR S.A.U. reserves the right to make modifications to the device or the unit specifications set out in this instruction manual without prior notice.

CIRCUTOR S.A.U. on its web site, supplies its customers with the latest versions of the device specifications and the most updated manuals.

www.circutor.com



CIRCUTOR S.A.U. recommends using the original cables and accessories that are supplied with the device.

CONTENTS

SAFETY PRECAUTIONS	3
DISCLAIMER	3
CONTENTS.....	4
REVISION LOG	7
SYMBOLS.....	8
1.- VERIFICATION UPON RECEPTION	9
2.- PRODUCT DESCRIPTION	9
3.- DEVICE INSTALLATION.....	11
3.1.- PRIOR RECOMMENDATIONS	11
3.2.- INSTALLATION	12
3.3.- PANEL MOUNTING ACCESSORY (72 x 72 mm)	12
3.4.- CVM-E3-MINI-FLEX: ROGOWSKI SENSORS.....	14
3.5.- DEVICE TERMINALS.....	15
3.5.1.- MODELS CVM-E3-MINI-ITF AND CVM-E3-MINI-MC	15
3.5.2.- MODEL CVM-E3-MINI-FLEX	15
3.5.3.- MODELS CVM-E3-MINI-ITF-WiEth AND CVM-E3-MINI-MC-WiEth	16
3.5.4.- MODEL CVM-E3-MINI-FLEX-WiEth.....	16
3.6.- CONNECTION DIAGRAM.....	17
3.6.1.- MEASURING THREE-PHASE NETWORKS WITH A 4-WIRE CONNECTION: CVM-E3-MINI-ITF AND CVM-E3-MINI-ITF-WiEth	17
3.6.2.- MEASURING THREE-PHASE NETWORKS WITH A 4-WIRE CONNECTION: CVM-E3-MINI-MC AND CVM-E3-MINI-MC-WiEth.	18
3.6.3.- MEASURING THREE-PHASE NETWORKS WITH A 4-WIRE CONNECTION: CVM-E3-MINI-FLEX AND CVM-E3-MINI-FLEX-WiEth.....	19
3.6.4.- MEASURING THREE-PHASE NETWORKS WITH A 3-WIRE CONNECTION: CVM-E3-MINI-ITF AND CVM-E3-MINI-ITF-WiEth.....	20
3.6.5.- MEASURING THREE-PHASE NETWORKS WITH A 3-WIRE CONNECTION: CVM-E3-MINI-MC AND CVM-E3-MINI-MC-WiEth.....	21
3.6.6.- MEASURING THREE-PHASE NETWORKS WITH A 3-WIRE CONNECTION: CVM-E3-MINI-FLEX AND CVM-E3-MINI-FLEX-WiEth	22
3.6.7.- MEASURING THREE-PHASE NETWORKS WITH A 3-WIRE CONNECTION AND TRANSFORMERS WITH AN ARON CONNECTION: CVM-E3-MINI-ITF AND CVM-E3-MINI-ITF-WiEth	23
3.6.8.- MEASURING THREE-PHASE NETWORKS WITH A 3-WIRE CONNECTION AND TRANSFORMERS WITH AN ARON CONNECTION: CVM-E3-MINI-MC AND CVM-E3-MINI-MC-WiEth	24
3.6.9.- MEASURING TWO-PHASE NETWORKS WITH A 3-WIRE CONNECTION: CVM-E3-MINI-ITF AND CVM-E3-MINI-ITF-WiEth.....	25
3.6.10.- MEASURING TWO-PHASE NETWORKS WITH A 3-WIRE CONNECTION: CVM-E3-MINI-MC AND CVM-E3-MINI-MC-WiEth	26
3.6.11.- MEASURING TWO-PHASE NETWORKS WITH A 3-WIRE CONNECTION: CVM-E3-MINI-FLEX AND CVM-E3-MINI-FLEX-WiEth.....	27
3.6.12.- MEASURING SINGLE-PHASE NETWORKS, PHASE TO PHASE, WITH A 2-WIRE CONNECTION: CVM-E3-MINI-ITF AND CVM-E3-MINI-ITF-WiEth	28
3.6.13.- MEASURING SINGLE-PHASE NETWORKS, PHASE TO PHASE, WITH A 2-WIRE CONNECTION: CVM-E3-MINI-MC AND CVM-E3-MINI-MC-WiEth	29
3.6.14.- MEASURING SINGLE-PHASE NETWORKS, PHASE TO PHASE, WITH A 2-WIRE CONNECTION: CVM-E3-MINI-FLEX AND CVM-E3-MINI-FLEX-WiEth.....	30
3.6.15.- MEASURING SINGLE-PHASE NETWORKS, PHASE TO NEUTRAL, WITH A 2-WIRE CONNECTION: CVM-E3-MINI-ITF AND CVM-E3-MINI-ITF-WiEth	31
3.6.16.- MEASURING SINGLE-PHASE NETWORKS, PHASE TO NEUTRAL, WITH A 2-WIRE CONNECTION: CVM-E3-MINI-MC AND CVM-E3-MINI-MC-WiEth	32
3.6.17.- MEASURING SINGLE-PHASE NETWORKS, PHASE TO NEUTRAL, WITH A 2-WIRE CONNECTION: CVM-E3-MINI-FLEX AND CVM-E3-MINI-FLEX-WiEth	33
4.- OPERATION.....	34
4.1.- MEASURING PARAMETERS	35
4.2.- KEYBOARD FUNCTIONS	37
4.3.- DISPLAY.....	38
4.4.- LED INDICATORS.....	39
4.5.- DIGITAL INPUT (Models CVM-E3-MINI-xxx).....	39
4.6.- DIGITAL OUTPUT (Models CVM-E3-MINI-xxx).....	40

5.- DISPLAY	41
5.1.- ANALYZER PROFILE	41
5.1.1.- MAXIMUM VALUES	44
5.1.2.- MINIMUM VALUES	44
5.1.3.- MAXIMUM DEMAND	44
5.1.4.- HARMONICS	44
5.1.5.- DETECTION OF INCORRECT CONNECTION AND INCORRECT DIRECTION OF ROTATION	45
5.2.- e ³ PROFILE	46
5.3.- DEVICE INFORMATION SCREENS	50
5.4.- DIGITAL INPUT AND OUTPUT STATUS SCREEN (Models CVM-E3-MINI-xxx)	50
5.5.- ETHERNET - WI-FI - BLUETOOTH® COMMUNICATIONS SCREENS (MODELS CVM-E3-MINI-XXX-WIETH)	51
5.5.1. Ethernet COMMUNICATIONS: DHCP CONFIGURATION	51
5.5.2. ETHERNET COMMUNICATIONS: IP ADDRESS	51
5.5.3. ETHERNET COMMUNICATIONS: IP MASK	52
5.5.4. ETHERNET COMMUNICATIONS: GATEWAY	53
5.5.5. ETHERNET COMMUNICATIONS: MAC ADDRESS	53
5.5.6. WI-FI COMMUNICATIONS: IP ADDRESS	54
5.5.7. WI-FI COMMUNICATIONS: MAC ADDRESS	54
5.5.8. WI-FI COMMUNICATIONS: SIGNAL LEVEL	54
5.5.9. Bluetooth® COMMUNICATIONS: NAME	55
6.- CONFIGURATION	56
6.1.- PRIMARY VOLTAGE	57
6.2.- SECONDARY VOLTAGE	57
6.3.- PRIMARY CURRENT	58
6.4.- SECONDARY CURRENT (MODEL CVM-E3-MINI-ITF)	59
6.5.- FLEX SENSOR	60
6.6.- NUMBER OF QUADRANTS	60
6.7.- MEASUREMENT CONVENTION	61
6.8.- MEASUREMENT SYSTEM	61
6.9.- MAXIMUM DEMAND INTEGRATION PERIOD	62
6.10.- DELETING MAXIMUM DEMAND	63
6.11.- DELETING MAXIMUM AND MINIMUM VALUES	64
6.12.- DELETING ENERGY VALUES	64
6.13.- ENABLE HARMONICS DISPLAY SCREEN	65
6.14.- kgCO ₂ CARBON EMISSION RATIO OF CONSUMED ENERGY	65
6.15.- kgCO ₂ CARBON EMISSION RATIO OF GENERATED ENERGY	66
6.16.- COST RATIO OF CONSUMED ENERGY	67
6.17.- COST RATIO OF GENERATED ENERGY	68
6.18.- PROGRAMMING ALARM : DIGITAL OUTPUT T1	69
6.18.1. MAXIMUM VALUE	71
6.18.2. MINIMUM VALUE	71
6.18.3. CONNECTION TIME DELAY	72
6.18.4. HYSTERESIS VALUE	72
6.18.5. LATCH	73
6.18.6. LATCH TIME	74
6.18.7. DISCONNECTION TIME DELAY	74
6.18.8. CONTACT STATUS	75
6.18.9. KILOWATTS PER PULSE	75
6.18.10. PULSE WIDTH	76
6.19.- OPERATING MODE OF DIGITAL INPUT (Models CVM-E3-MINI-xxx)	77
6.20.- TARIFF SELECTION (Models CVM-E3-MINI-xxx-WiEth)	78
6.21.- BACKLIGHT, TURNING ON THE BACKLIT DISPLAY	78
6.22.- RS-485 COMMUNICATIONS (Models CVM-E3-MINI-xxx)	79
6.22.1.- MODBUS PROTOCOL: BAUD RATE	80
6.22.2.- MODBUS PROTOCOL: PERIPHERAL NUMBER	80
6.22.3.- MODBUS PROTOCOL: PARITY	81
6.22.4.- MODBUS PROTOCOL: DATA BITS	82
6.22.5.- MODBUS PROTOCOL : STOP BITS	82
6.22.6.- BACnet PROTOCOL : BAUD RATE	83
6.22.7.- BACnet PROTOCOL : ID	83
6.22.8.- BACnet PROTOCOL : MAC ADDRESS	84

6.23.- LOCKING THE PROGRAMMING.....	85
6.23.1.- PASSWORD.....	86
7.- CVM-E3-MINI-XXX : RS-485 COMMUNICATIONS	87
7.1.- CONNECTIONS.....	87
7.2.- MODBUS PROTOCOL.....	88
7.2.1.- READING EXAMPLE : Funtion 0x04.....	88
7.2.2.- WRITING EXAMPLE : Funtion 0x05.....	88
7.3.- MODBUS COMMANDS	89
7.3.1. MEASUREMENT VARIABLES	89
7.3.2. ENERGY VARIABLES	92
7.3.3. VOLTAGE AND CURRENT HARMONICS.....	94
7.3.4. DELETING PARAMETERS.....	98
7.3.5. POWER STATUS.....	98
7.3.6. DETECTION OF INCORRECT DIRECTION OF ROTATION.....	99
7.3.7. DEVICE SERIAL NUMBER.....	99
7.3.8. DIGITAL INPUT: PULSE COUNTER.....	99
7.3.9. DEVICE CONFIGURATION VARIABLES.....	99
7.4.- BACnet PROTOCOL.....	104
7.4.1.- MAPA PICS	105
8.- CVM-E3-MINI-XXX-WIETH : COMMUNICATIONS.....	108
8.1.- USAGE ENVIRONMENT AND HEALTH	108
8.2.- Wi-Fi COMMUNICATIONS.....	108
8.3.- Bluetooth® COMMUNICATIONS.....	109
8.4.- MOBILE APP	109
8.5.- CONFIGURATION WEB PAGE	110
9.- TECHNICAL FEATURES.....	113
10.- MAINTENANCE AND TECHNICAL SERVICE.....	117
11.- GUARANTEE	117
12.- EU DECLARATION OF CONFORMITY.....	118
ANNEX A.- CONFIGURATION MENUS.....	121

Note: Devices images are for illustrative purposes only and may differ from the actual device.





REVISION LOG

Table 1: Revision log.

Date	Revision	Description
12/17	M170B01-03-17A	Initial Version
02/18	M170B01-03-18A	Changes in the following sections: 3.3. - 6.17.- 10.
04/18	M170B01-03-18B	Changes in the following sections: 3.2.- 3.5. - 5.1.5 - 7.3.6.
09/18	M170B01-03-18B	Changes in the following sections: 2.- 3.2.- 3.4.- 3.5.- 3.6.- 5.- 5.1.4.- 6.4.- 6.7.- 7.3.1.- 7.3.7.1.- 7.3.7.4.- 7.4.1.- 8.
12/18	M170B01-03-18D	Changes in the following sections: 6.1. - 6.2.- 6.4.- 7.3.7.13.
02/19	M170B01-03-19A	Changes in the following sections: 7.3.1. - 8.
03/19	M170B01-03-19B	Changes in the following sections: 3.6.2.- 3.6.5.
03/19	M170B01-03-19C	Changes in the following sections: 3.6.3.- 3.6.6.- 3.6.11.- 3.6.14.- 3.6.17.
08/19	M170B01-03-19D	Logo modification and corporate colors.
10/19	M170B01-03-19E	Changes in the following sections: 2.- 3.5.- 3.6.- 4.2.- 4.5.- 4.6.- 5.4.- 5.5.- 6.3.- 6.4.- 6.5.- 6.7.- 6.8.- 6.17.- 6.19.- 6.20.- - 6.22.- 7.- 7.3.7.1.- 7.3.7.4.- 7.3.7.10.- 7.3.7.11 - 7.3.7.12.- 7.3.7.13.- 7.3.7.14.- 8.- 9.
05/20	M170B01-03-20A	Changes in the following sections: 9.
06/20	M170B01-03-20B	Changes in the following sections: 7.3.1. - 7.3.2.
10/20	M170B01-03-20C	Changes in the following sections: 5.5.6.- 8.4.- 9.
12/20	M170B01-03-20D	Changes in the following sections: 3.5.1.- 3.5.2.- 7.3.1.- 9.
06/21	M170B01-03-21A	Changes in the following sections: 9.
03/22	M170B01-03-22A	Changes in the following sections: 6.22.1.- 6.22.6.- 7.3.7.- 7.3.8.15.- 9.-Annex A
12/22	M170B01-03-22B	Changes in the following sections: 2.- 4.1.- 4.5.- 6.18.6.- 6.19.- 6.22.1.- 6.22.6.- 7.3.1.- 7.3.2.- 7.3.4.- 7.3.8.- 7.3.9.8.- 7.3.9.11.- 7.3.9.12.- 7.3.9.15.- 9.- Annex A
07/23	M170B01-03-23A	Changes in the following sections: 3.4.- 3.6.3.- 3.6.11.- 3.6.14.- 3.6.17.
10/23	M170B01-03-23B	Changes in the following sections: 8.4.- 8.5.- 9.
01/24	M170B01-03-24A	Changes in the following sections: 7.3.- 9.

SYMBOLS

Table 2: Symbols

Symbol	Description
	In compliance with the relevant European directive.
	Wireless communications using the Bluetooth® protocol.
	Device covered by European directive 2012/19/EC. At the end of its useful life, do not leave the unit in a household waste container. Follow local regulations on electronic equipment recycling.
	DC current
	AC current

1.- VERIFICATION UPON RECEPTION

Check the following points when you receive the device:

- a) The device meets the specifications described in your order.
- b) The device has not suffered any damage during transport.
- c) Perform an external visual inspection of the device prior to switching it on.
- d) Check that it has been delivered with the following:
 - An installation guide,
 - 1 retainer to secure the device to the DIN rail,
 - 4 connectors.
 - 2 terminal covers.



If any problem is noticed upon reception, immediately contact the transport company and/or **CIRCUTOR's** after-sales service.

2.- PRODUCT DESCRIPTION

The **CVM-E3-MINI** device measures, calculates and displays the main electrical parameters of the following networks: single-phase, two-phase, with and without neutral, balanced three-phase, with ARON measurements or unbalanced. The measurement will be taken in RMS with the three AC voltage inputs and three current inputs.

There are 6 versions of the device, in accordance with current input:

- ✓ **CVM-E3-MINI-ITF** and **CVM-E3-MINI-ITF-WiEth**, indirect current measurement with /5A or /1A transformers.
- ✓ **CVM-E3-MINI-MC** and **CVM-E3-MINI-MC-WiEth**, indirect current measurement with efficient MC1 and MC3 series transformers.
- ✓ **CVM-E3-MINI-FLEX** and **CVM-E3-MINI-FLEX-WiEth**, current measurement through Rogowski sensors.



Table 3: Models.

Models	Pulse outputs	Digital input	Communications			
			RS-485	Ethernet	Wi-Fi	Bluetooth®
CVM-E3-MINI-ITF	✓	✓	✓			
CVM-E3-MINI-ITF-WiEth				✓	✓	✓
CVM-E3-MINI-MC	✓	✓	✓			
CVM-E3-MINI-MC-WiEth				✓	✓	✓
CVM-E3-MINI-FLEX	✓	✓	✓			
CVM-E3-MINI-FLEX-WiEth				✓	✓	✓

The device features:

- **3 keys** that allow you to browse between the various screens and program the device.
- **2 indicator LEDs:** CPU and ALARM.
- **LCD display**, displays all parameters.

Note: *Devices with software version v1.xx cannot be upgraded to version v2.xx and vice versa.*

3.- DEVICE INSTALLATION

3.1.- PRIOR RECOMMENDATIONS



In order to use the device safely, it is critical that individuals who handle it follow the safety measures set out in the standards of the country where it is being used, use the necessary personal protective equipment, and pay attention to the various warnings indicated in this instruction manual.

The **CVM-E3-MINI** device must be installed by authorised and qualified staff.

The power supply plug must be disconnected and measuring systems switched off before handling, altering the connections or replacing the device. It is dangerous to handle the device while it is powered.

Also, it is critical to keep the cables in perfect condition in order to avoid accidents, personal injury and damage to installations.

The manufacturer of the device is not responsible for any damage resulting from failure by the user or installer to heed the warnings and/or recommendations set out in this manual, nor for damage resulting from the use of non-original products or accessories or those made by other manufacturers.

If an anomaly or malfunction is detected in the device, do not use it to take any measurements.

Inspect the work area before taking any measurements. Do not take measurements in dangerous areas or where there is a risk of explosion.



Disconnect the device from the power supply (device and measuring system power supply) before maintaining, repairing or handling the device's connections. Please contact the after-sales service if you suspect that there is an operational fault in the device.

3.2.- INSTALLATION

The device must be installed on an electric panel or enclosure, attached to a DIN rail (IEC 60715).

The minimum recommended distance between rails for installing the **CVM-E3-MINI** device is 150 mm.



Terminals, opening covers or removing elements can expose parts that are hazardous to the touch while the device is powered. Do not use the device until it is fully installed.

The device must be connected to a power circuit that is protected with gI (IEC 269) or M type fuses with a rating of 0.5 to 2 A. It must be fitted with a circuit breaker or equivalent device, in order to be able to disconnect the device from the power supply network.

The power and voltage measuring circuit must be connected with cables that have a minimum cross-section of 1mm².

The secondary line of the current transformer will have a minimum cross-section of 2.5 mm².

The temperature rating of insulation of wires connected to the device will be at minimum 62°C.

3.3.- PANEL MOUNTING ACCESSORY (72 x 72 mm)

Note: The 72 x 72 mm panel mounting accessory is an accessory that is sold separately.

CIRCUTOR has a panel mounting accessory of the **CVM-E3-MINI** equipment so that it can be installed on 72 x 72 mm panels.



Figure 1: CVM-E3-MINI with panel mounting accessory.

Figure 2 shows the installation of the panel mounting accessory to the **CVM-E3-MINI**.



Disconnect all power supplies and measuring equipment from the device before carrying out the installation of the panel mounting accessory.

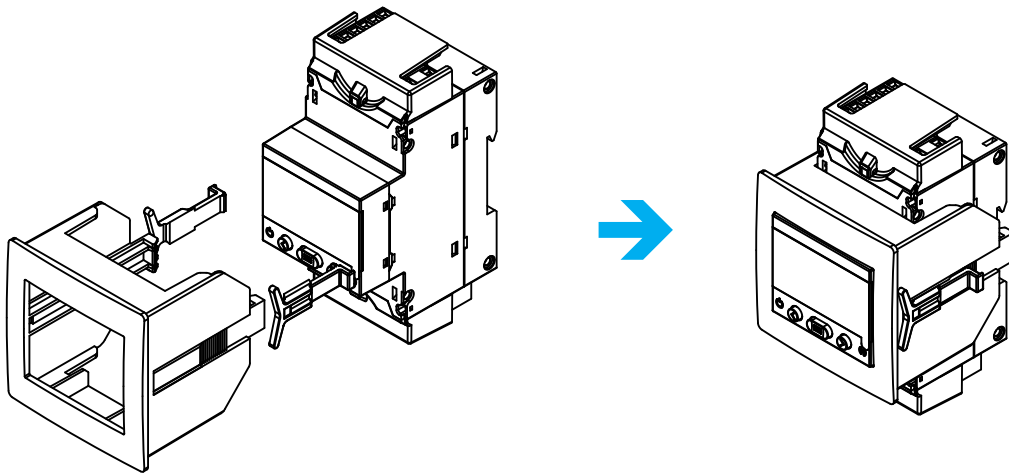

Figure 2: Installation of the panel mounting accessory.

Table 4: Technical features.

Technical features	
Protection degree	IP40
Enclosure	Self-extinguishing V0 plastic

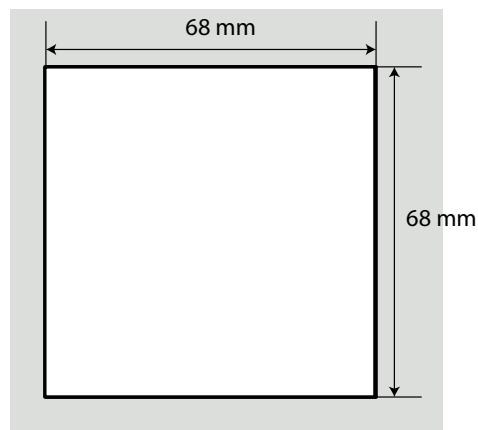

Figure 3: Panel cut-out.

3.4.- CVM-E3-MINI-FLEX: ROGOWSKI SENSORS

The **CVM-E3-MINI-FLEX** model measures currents using flexible sensors, based on the Rogowski coil principle.

The flexibility of the sensor allows it to measure an alternating current irrespective of the position of the conductor.

CIRCUTOR has 2 Rogowski sensor model that can be used with the **CVM-E3-MINI-FLEX: FLEX-MAG** and **MFC-FLEX**.

Note: For more information, consult the corresponding sensor guide.

Table 5: Position error.



Position		Error	
		FLEX-MAG	MFC-FLEX
	A	± 1%	< 1%
	B	A ± 3%	< 1%

Table 6: Probe cable terminal connections

Probe cable terminal connections	
FLEX-MAG	
	Shield Común / Common Canal de medida / Measuring channel
<p>Black : Shield (SHLD) Blue: Common (C) Green: Measuring channel (L1, L2, L3, N)</p>	
MFC-FLEX	
	OUT+ OUT- Blindaje / Shield
<p>White (OUT+): Measuring channel (L1, L2, L3, N) Blue (OUT-): Common (C) Grey: Shield (SHLD)</p>	

3.5.- DEVICE TERMINALS

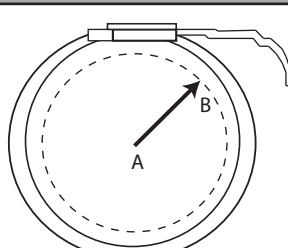
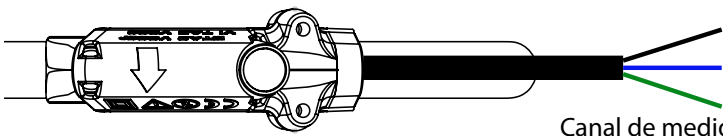
3.5.1.- MODELS CVM-E3-MINI-ITF AND CVM-E3-MINI-MC

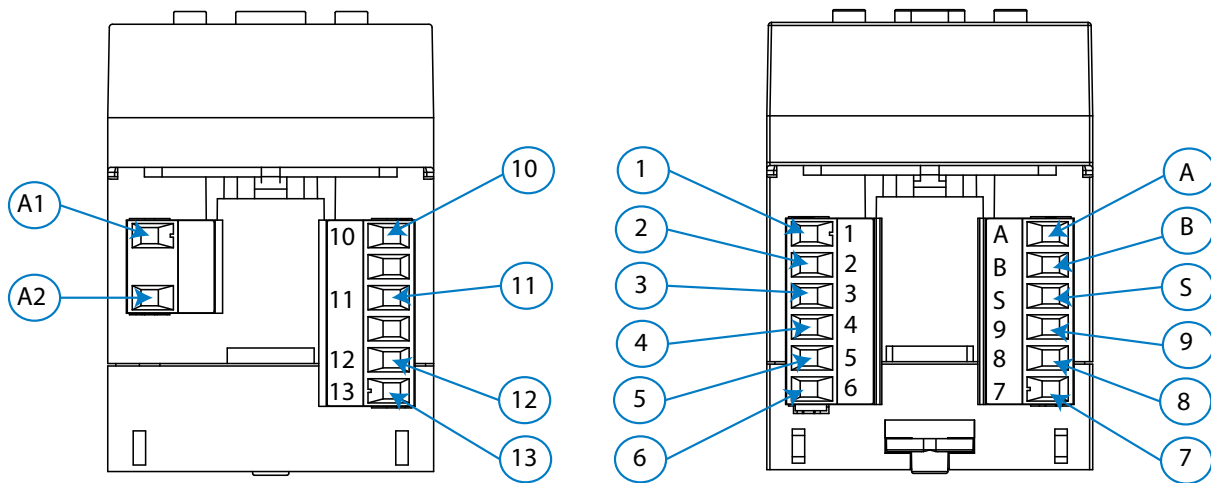

Figure 4: CVM-E3-MINI-ITF / -MC / -FLEX terminals: Up - Down

Table 7: Device terminals: CVM-E3-MINI-ITF and CVM-E3-MINI-MC

Device terminals	
A1: ~ +, Power supply	4: S2, current input L2
A2: ~ -, Power supply	5: S1, current input L3
10: VL1, voltage input L1	6: S2, current input L3
11: VL2, voltage input L2	A: A+, RS-485
12: VL3, voltage input L3	B: B-, RS-485
13: N, Neutral voltage input	S: S, GND for RS-485 and digital inputs
1: S1, current input L1	9: I1, Digital input 1 or selection rate
2: S2, current input L1	8: O1, Digital output 1
3: S1, current input L2	7: CO, Common digital outputs

3.5.2.- MODEL CVM-E3-MINI-FLEX

Table 8: Device terminals: CVM-E3-MINI-FLEX

Device terminals	
A1: ~ +, Power supply	4: Without connecting
A2: ~ -, Power supply	5: C, Common current input
10: VL1, voltage input L1	6: SHLD, GND for current inputs
11: VL2, voltage input L2	A: A+, RS-485
12: VL3, voltage input L3	B: B-, RS-485
13: N, Neutral voltage input	S: S, GND for RS-485 and digital inputs
1: L1, current input L1	9: I1, Digital input 1 or selection rate
2: L2, current input L2	8: O1, Digital output 1
3: L3, current input L3	7: CO, Common digital outputs

3.5.3.- MODELS CVM-E3-MINI-ITF-WiEth AND CVM-E3-MINI-MC-WiEth

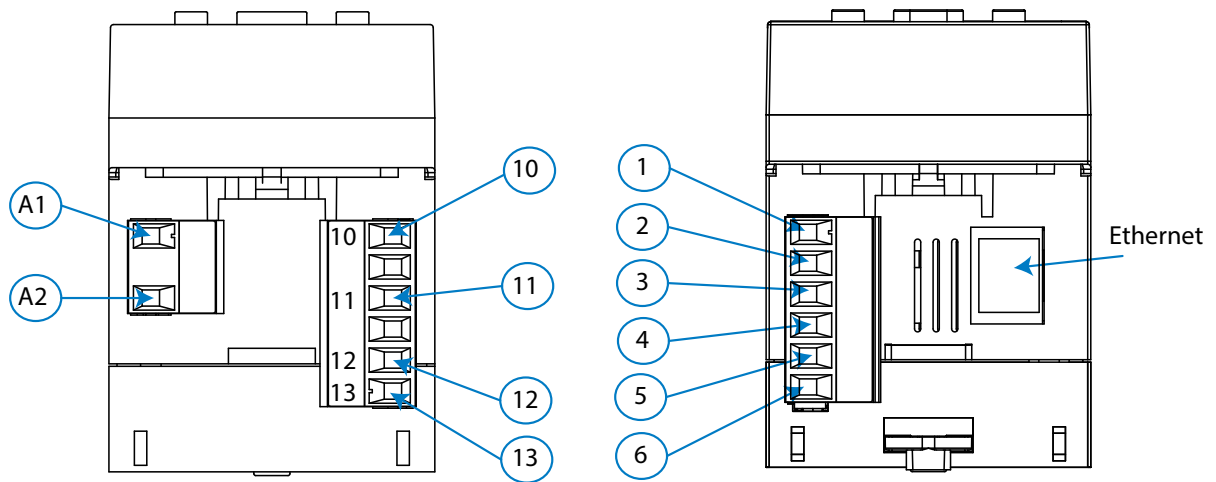

Figure 5: CVM-E3-MINI-ITF/-MC/-FLEX-WiEth terminals: Up - Down.

Table 9: Device terminals: CVM-E3-MINI-ITF-WiEth and CVM-E3-MINI-MC-WiEth

Device terminals	
A1: ~ +, Power supply	2: S2, current input L1
A2: ~ -, Power supply	3: S1, current input L2
10: VL1, voltage input L1	4: S2, current input L2
11: VL2, voltage input L2	5: S1, current input L3
12: VL3, voltage input L3	6: S2, current input L3
13: N, Neutral voltage input	Ethernet: Ethernet connection
1: S1, current input L1	

3.5.4.- MODEL CVM-E3-MINI-FLEX-WiEth

Table 10: Device terminals: CVM-E3-MINI-FLEX-WiEth

Device terminals	
A1: ~ +, Power supply	2: L2, current input L2
A2: ~ -, Power supply	3: L3, current input L3
10: VL1, voltage input L1	4: Without connecting
11: VL2, voltage input L2	5: C, Common current input
12: VL3, voltage input L3	6: SHLD, GND for current inputs
13: N, Neutral voltage input	Ethernet: Ethernet connection
1: L1, current input L1	

3.6.- CONNECTION DIAGRAM

3.6.1.- MEASURING THREE-PHASE NETWORKS WITH A 4-WIRE CONNECTION: CVM-E3-MINI-ITF AND CVM-E3-MINI-ITF-WiEth

Measurement system: 4-3Ph

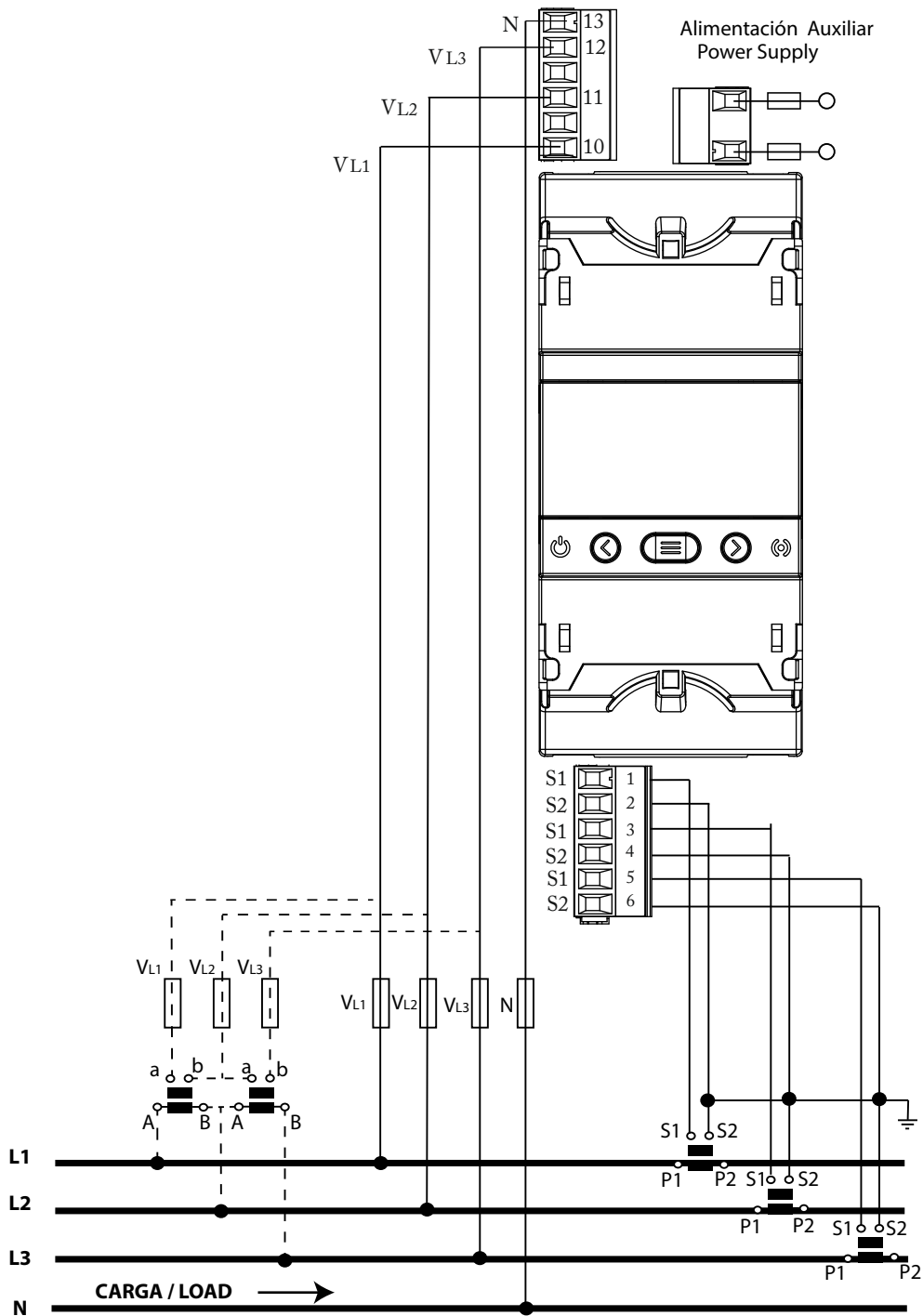

Figure 6: Three-Phase measuring with a 4-wire connection: CVM-E3-MINI-ITF and CVM-E3-MINI-ITF-WiEth.



To guarantee the insulation of the device and its category, it is necessary to earth the S2 terminals of the transformers.

3.6.2.- MEASURING THREE-PHASE NETWORKS WITH A 4-WIRE CONNECTION: CVM-E3-MINI-MC AND CVM-E3-MINI-MC-WiEth.

Measurement system: 4-3Ph

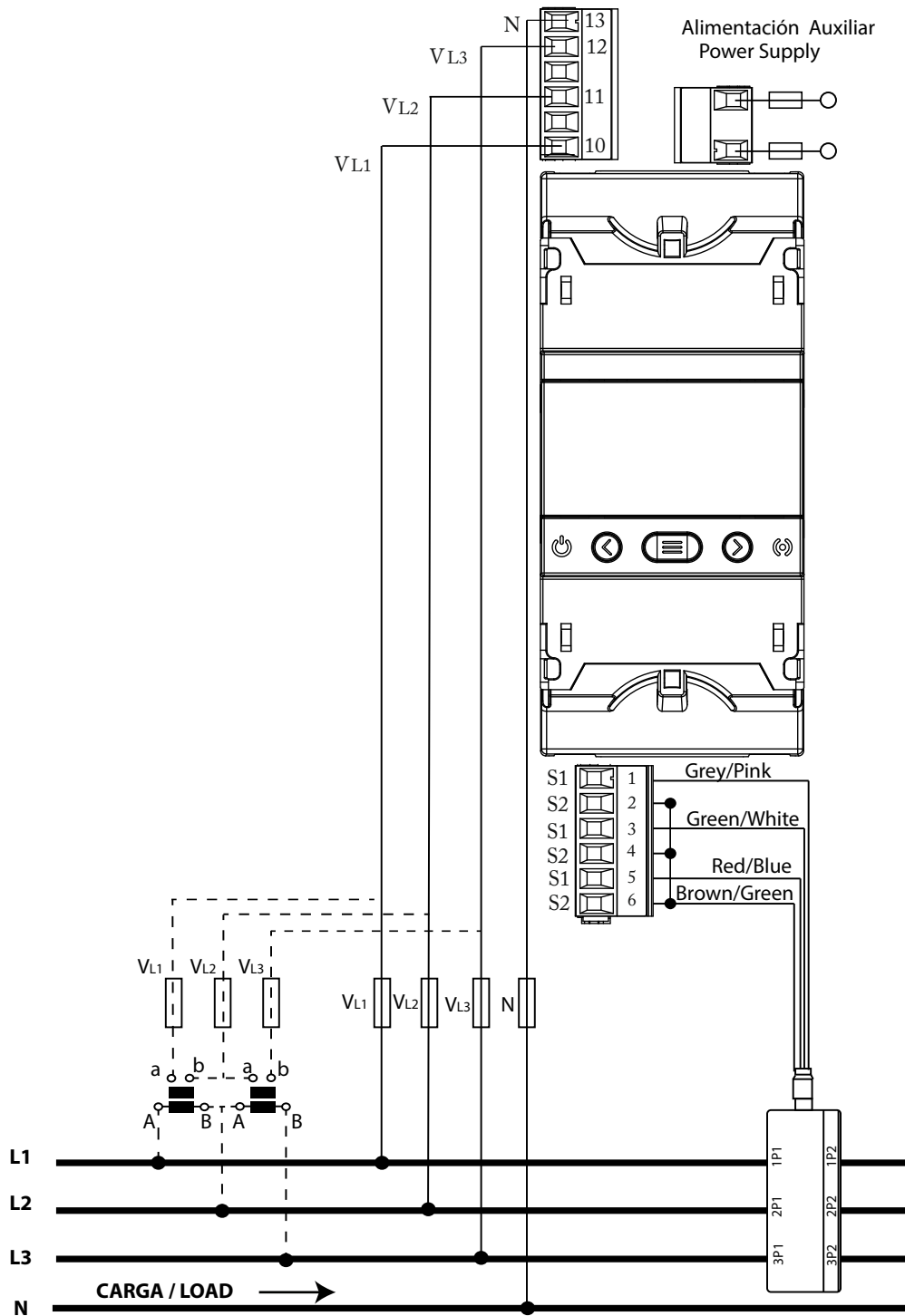

Figure 7: Three-Phase measuring with a 4-wire connection: CVM-E3-MINI-MC and CVM-E3-MINI-MC-WiEth.

Note: Do not connect MC current transformers to ground.

The MC transformer secondary value is set to 0.250 A (fixed value).

3.6.3.- MEASURING THREE-PHASE NETWORKS WITH A 4-WIRE CONNECTION: CVM-E3-MINI-FLEX AND CVM-E3-MINI-FLEX-WiEth

Measurement system: 4-3Ph

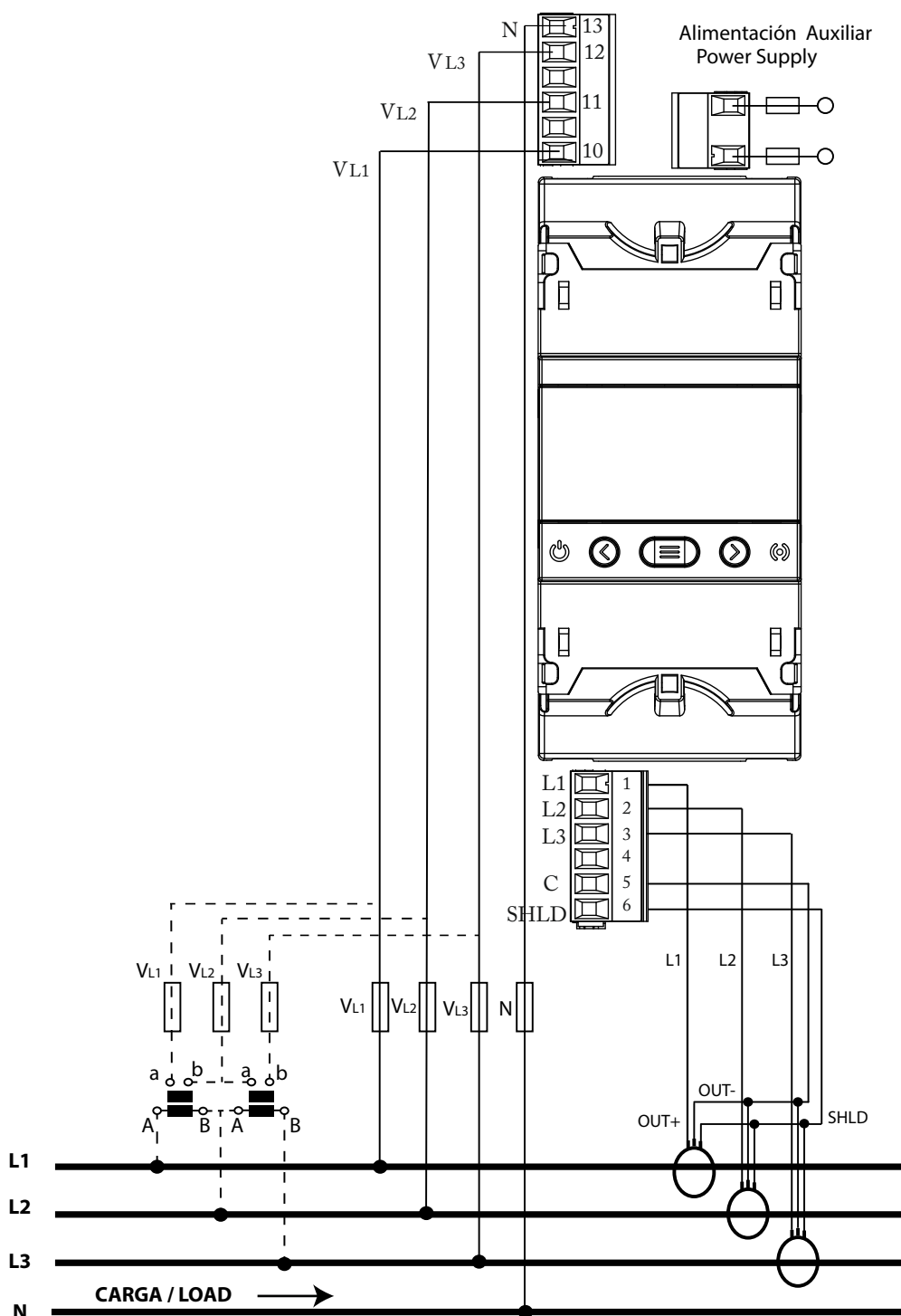

Figure 8: Three-Phase measuring with a 4-wire connection: CVM-E3-MINI-FLEX and CVM-E3-MINI-FLEX-WiEth.

It is mandatory connect the **SHLD** terminal of the probe.

3.6.4.- MEASURING THREE-PHASE NETWORKS WITH A 3-WIRE CONNECTION: CVM-E3-MINI-ITF AND CVM-E3-MINI-ITF-WiEth

Measurement system: 3-3Ph

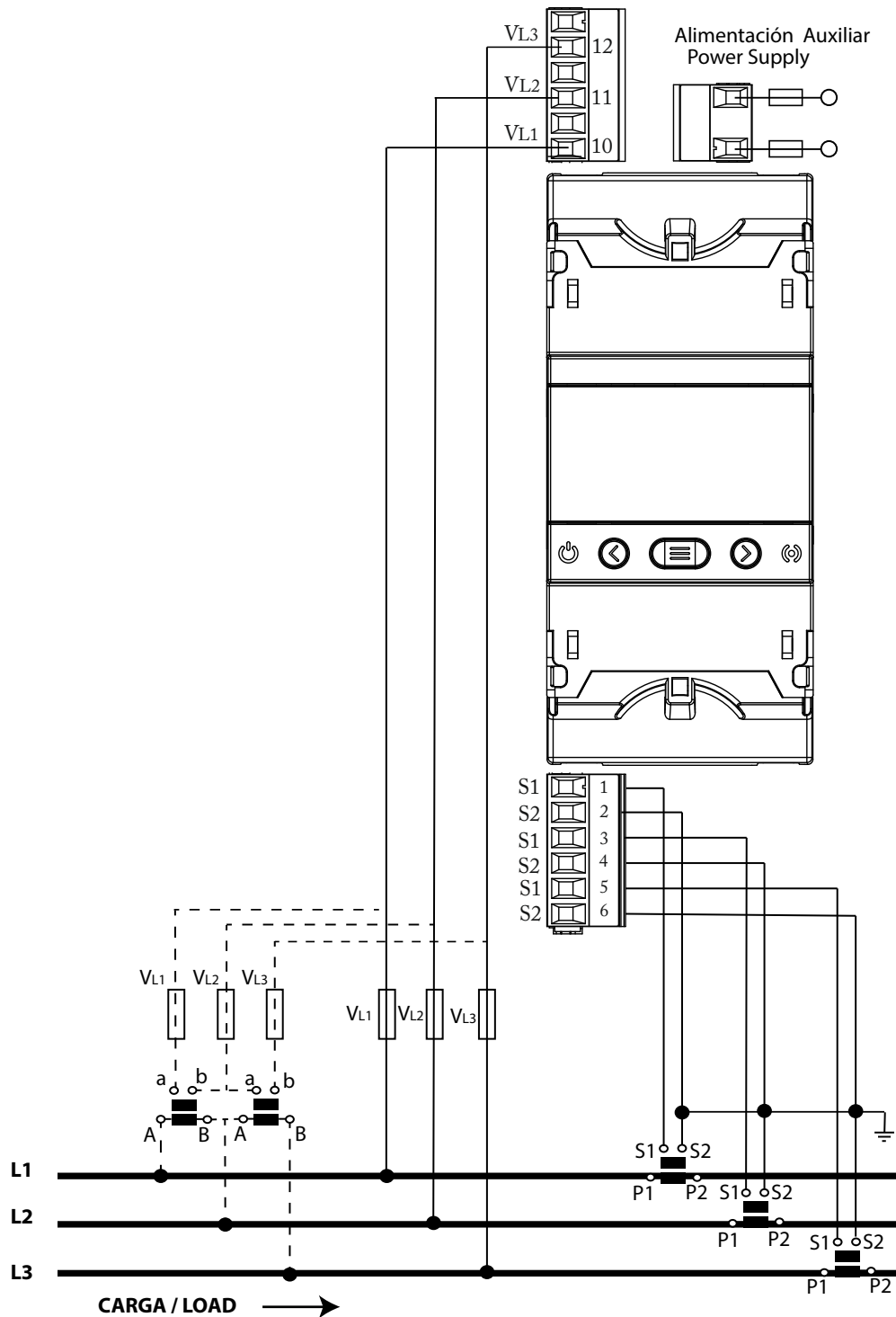

Figure 9: Three-Phase measuring with a 3-wire connection: CVM-E3-MINI-ITF and CVM-E3-MINI-ITF-WiEth.



To guarantee the insulation of the device and its category, it is necessary to earth the S2 terminals of the transformers.

3.6.5.- MEASURING THREE-PHASE NETWORKS WITH A 3-WIRE CONNECTION: CVM-E3-MINI-MC AND CVM-E3-MINI-MC-WiEth

Measurement system: 3-3Ph

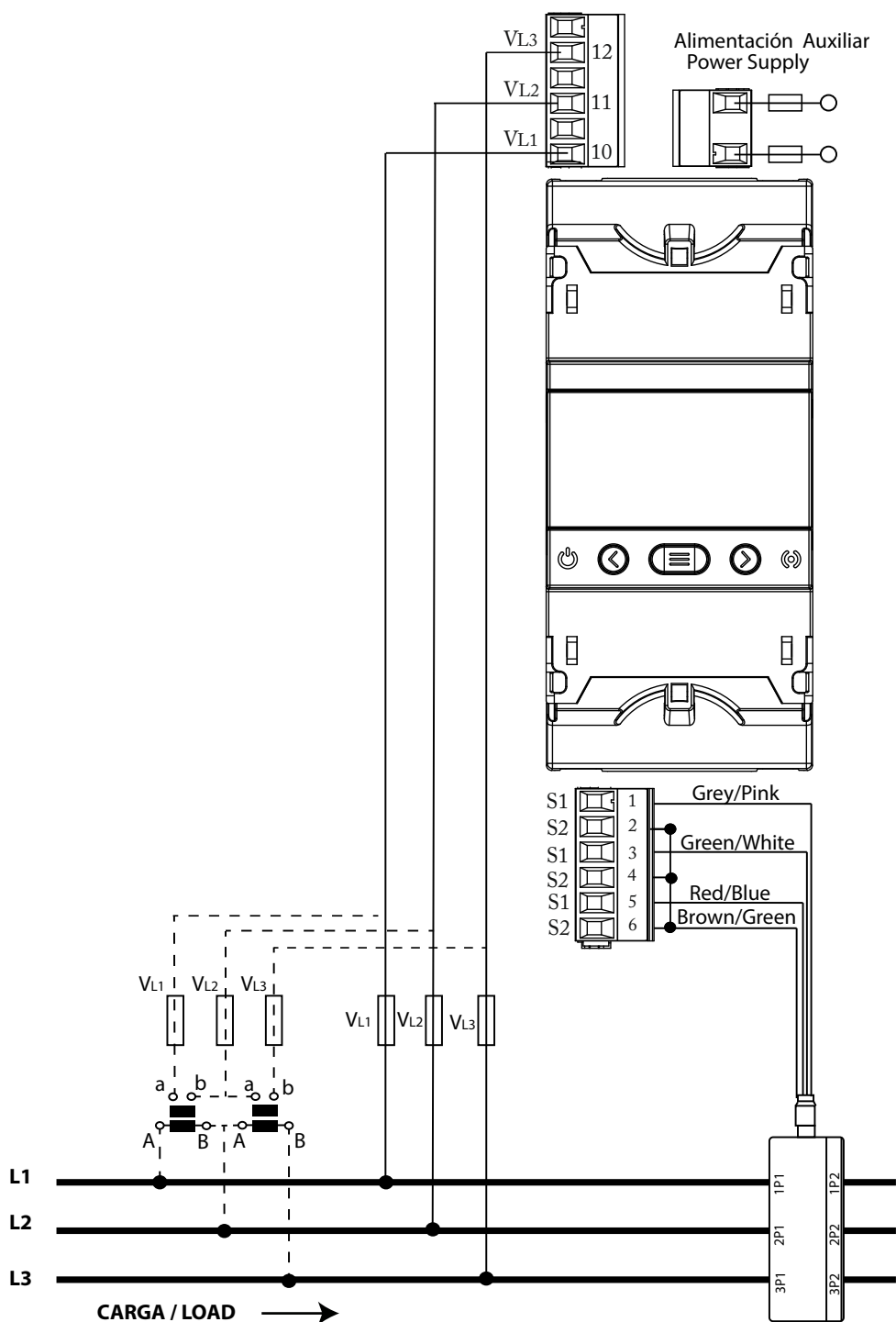

Figure 10: Three-Phase measuring with a 3-wire connection: CVM-E3-MINI-MC and CVM-E3-MINI-MC-WiEth.

Note: Do not connect MC current transformers to ground.

The MC transformer secondary value is set to 0.250 A (fixed value).

3.6.6.- MEASURING THREE-PHASE NETWORKS WITH A 3-WIRE CONNECTION: CVM-E3-MINI-FLEX AND CVM-E3-MINI-FLEX-WiEth

Measurement system: 3-3Ph

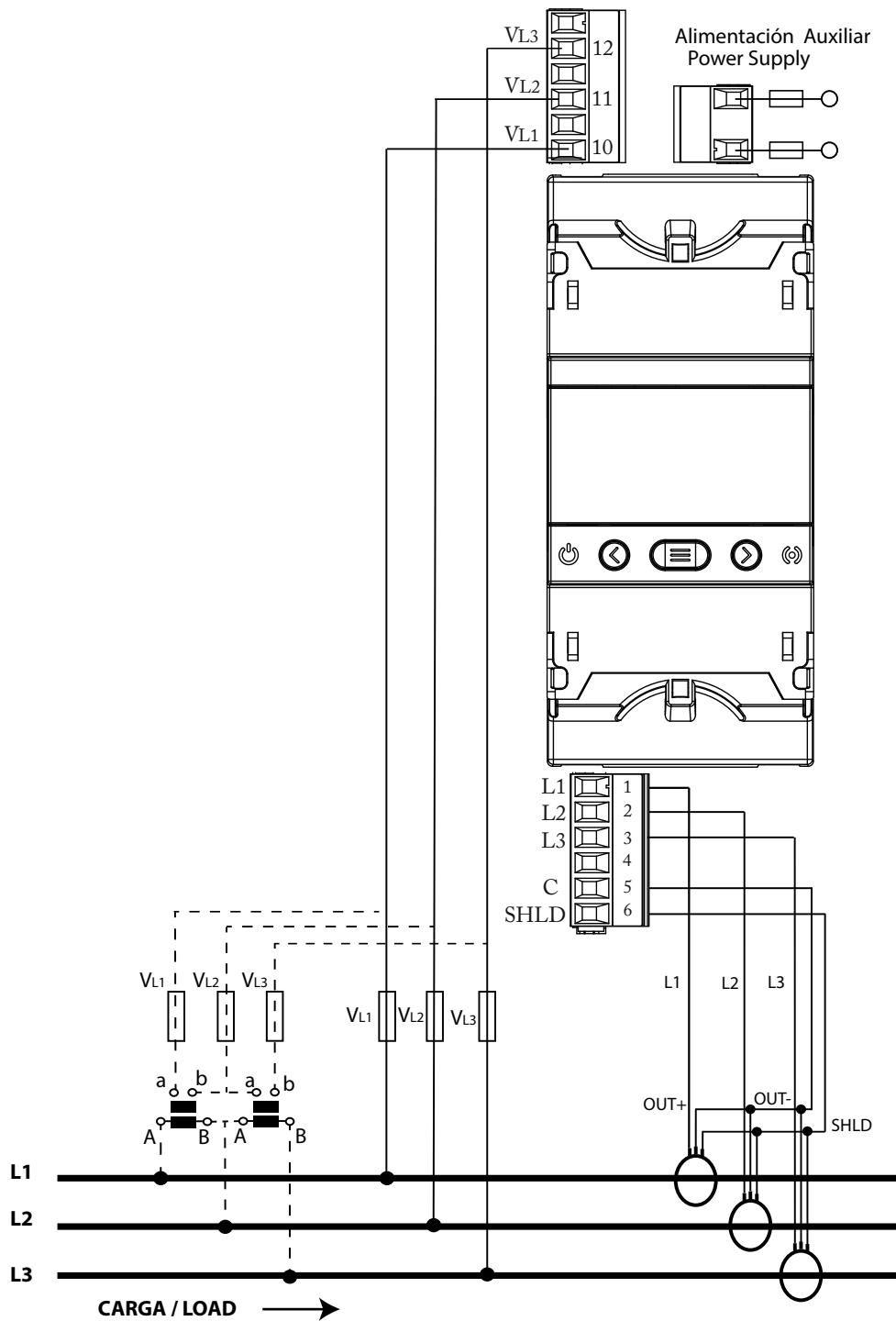

Figure 11: Three-Phase measuring with a 3-wire connection: CVM-E3-MINI-FLEX and CVM-E3-MINI-FLEX-WiEth.



It is mandatory connect the **SHLD** terminal of the probe.

3.6.7.- MEASURING THREE-PHASE NETWORKS WITH A 3-WIRE CONNECTION AND TRANSFORMERS WITH AN ARON CONNECTION: CVM-E3-MINI-ITF AND CVM-E3-MINI-ITF-Wieth

Measurement system: \exists -Ar-0n

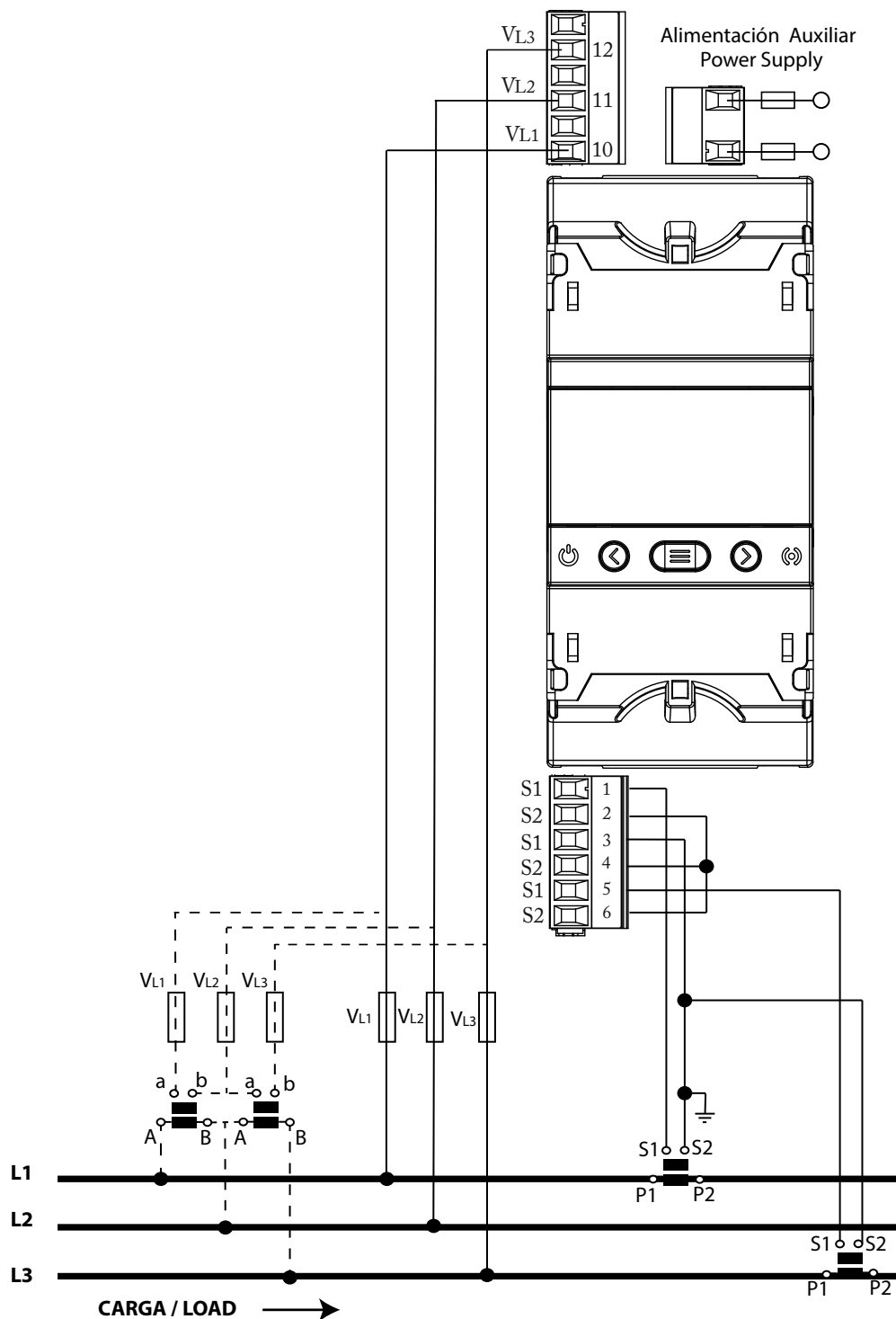

Figure 12: Three-Phase measuring with a 3-wire connection and transformers with an ARON connection: CVM-E3-MINI-ITF and CVM-E3-MINI-ITF-Wieth.



To guarantee the insulation of the device and its category, it is necessary to earth the S2 terminals of the transformers.

3.6.8.- MEASURING THREE-PHASE NETWORKS WITH A 3-WIRE CONNECTION AND TRANSFORMERS WITH AN ARON CONNECTION: CVM-E3-MINI-MC AND CVM-E3-MINI-MC-WiEth

Measurement system: 3-ARON

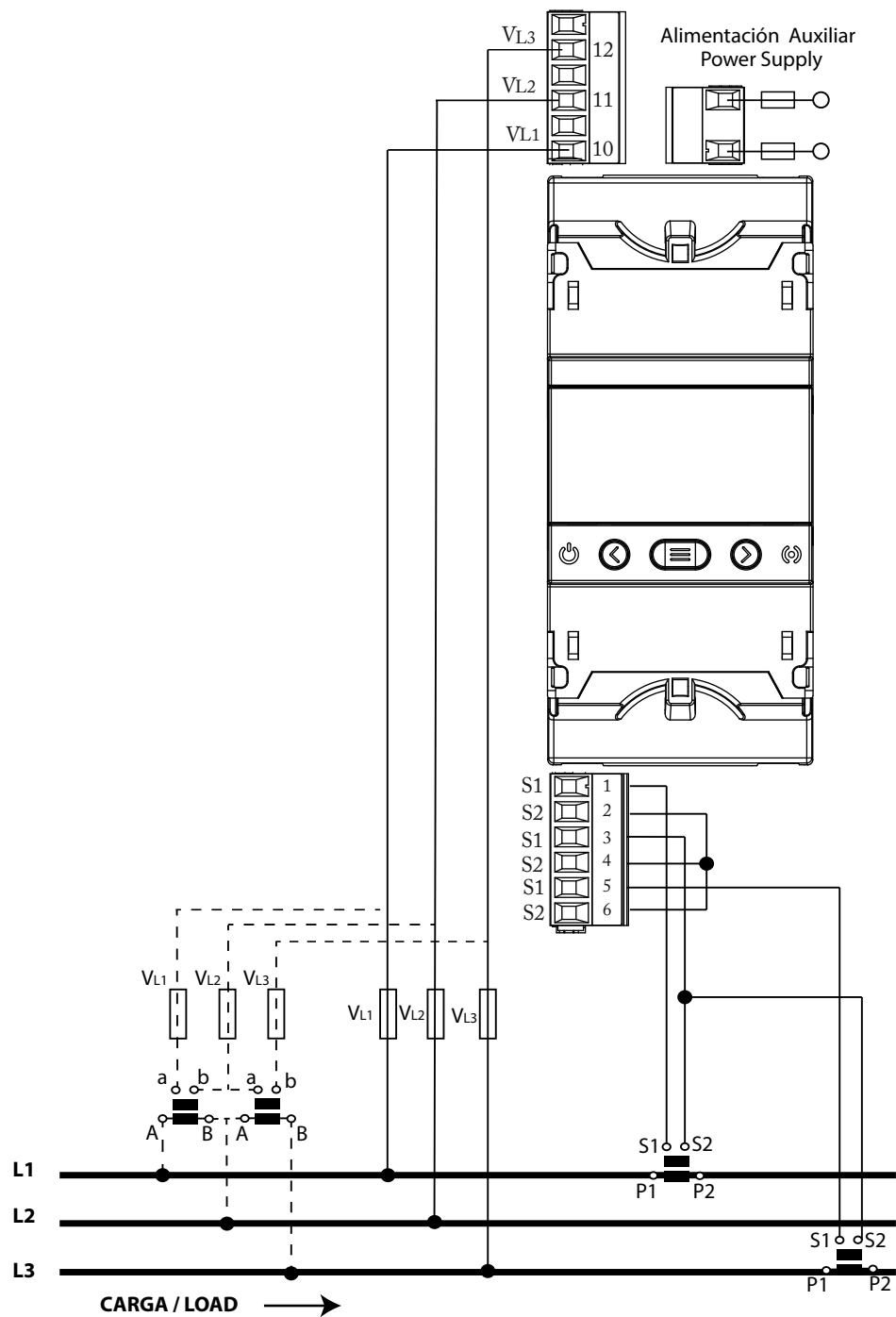

Figure 13: Three-Phase measuring with a 3-wire connection and transformers with an ARON connection: CVM-E3-MINI-MC and CVM-E3-MINI-MC-WiEth.

Note: Do not connect MC current transformers to ground.

The MC transformer secondary value is set to 0.250 A (fixed value).

3.6.9.- MEASURING TWO-PHASE NETWORKS WITH A 3-WIRE CONNECTION: CVM-E3-MINI-ITF AND CVM-E3-MINI-ITF-WiEth

Measurement system: 3-2Ph

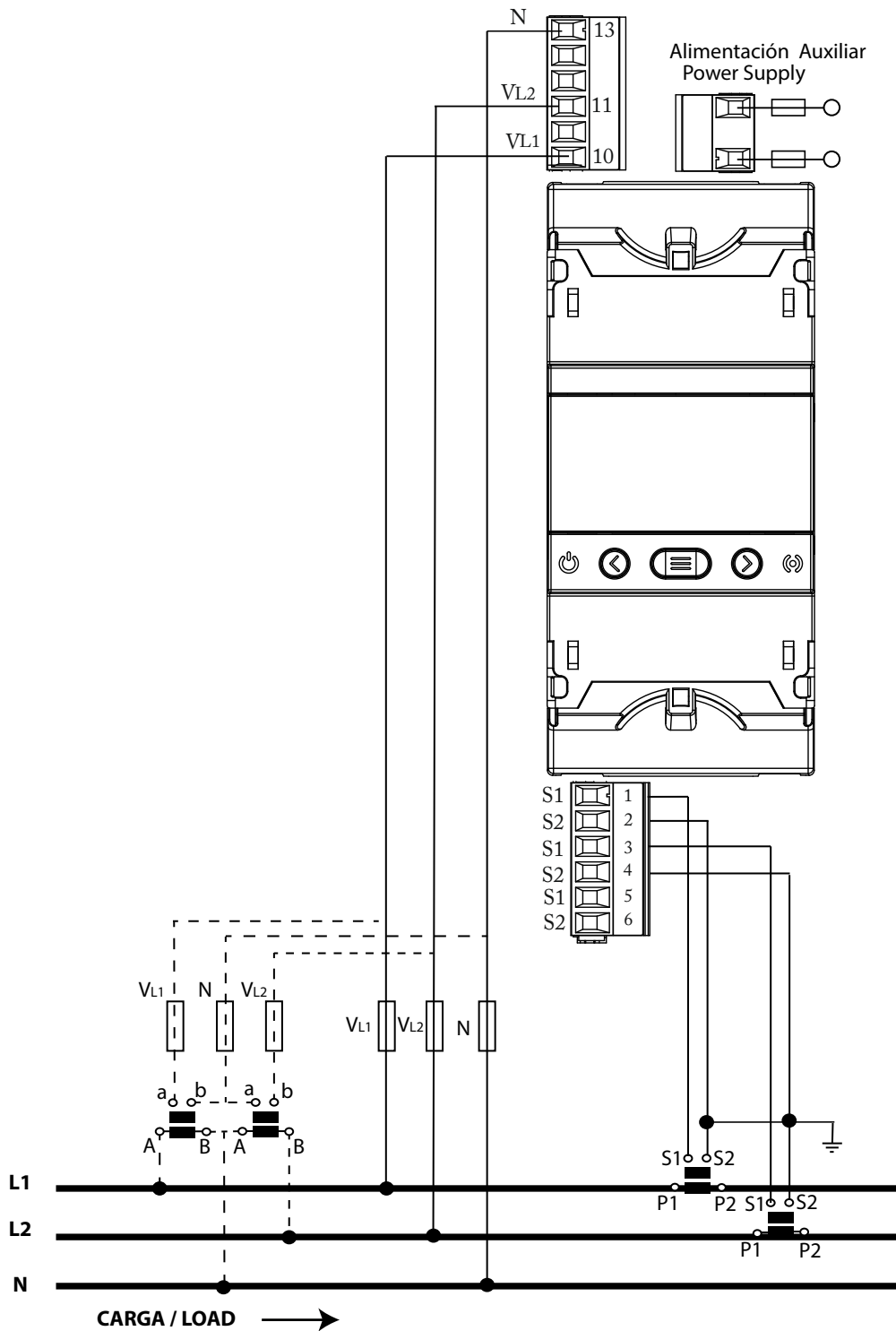



Figure 14: Measuring Two-Phase Networks with a 3-wire connection: CVM-E3-MINI-ITF and CVM-E3-MINI-ITF-WiEth.



To guarantee the insulation of the device and its category, it is necessary to earth the S2 terminals of the transformers.

3.6.10.- MEASURING TWO-PHASE NETWORKS WITH A 3-WIRE CONNECTION: CVM-E3-MINI-MC AND CVM-E3-MINI-MC-WiEth

Measurement system: 3-2Ph

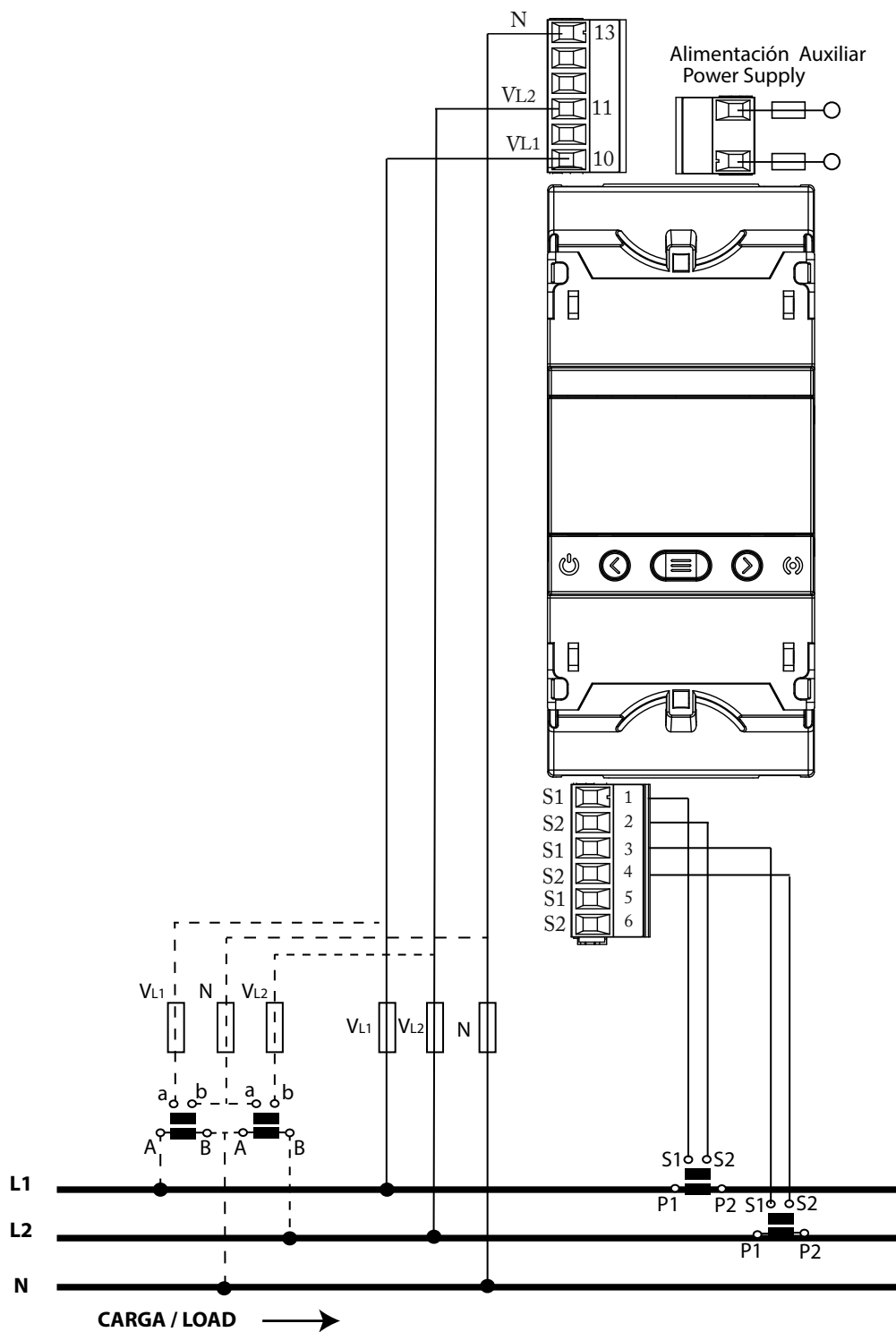

Figure 15: Measuring Two-Phase Networks with a 3-wire connection: CVM-E3-MINI-MC and CVM-E3-MINI-MC-WiEth.

Note: Do not connect MC current transformers to ground.



The MC transformer secondary value is set to 0.250 A (fixed value).

3.6.11.- MEASURING TWO-PHASE NETWORKS WITH A 3-WIRE CONNECTION: CVM-E3-MINI-FLEX AND CVM-E3-MINI-FLEX-WiEth

Measurement system: 3-2Ph

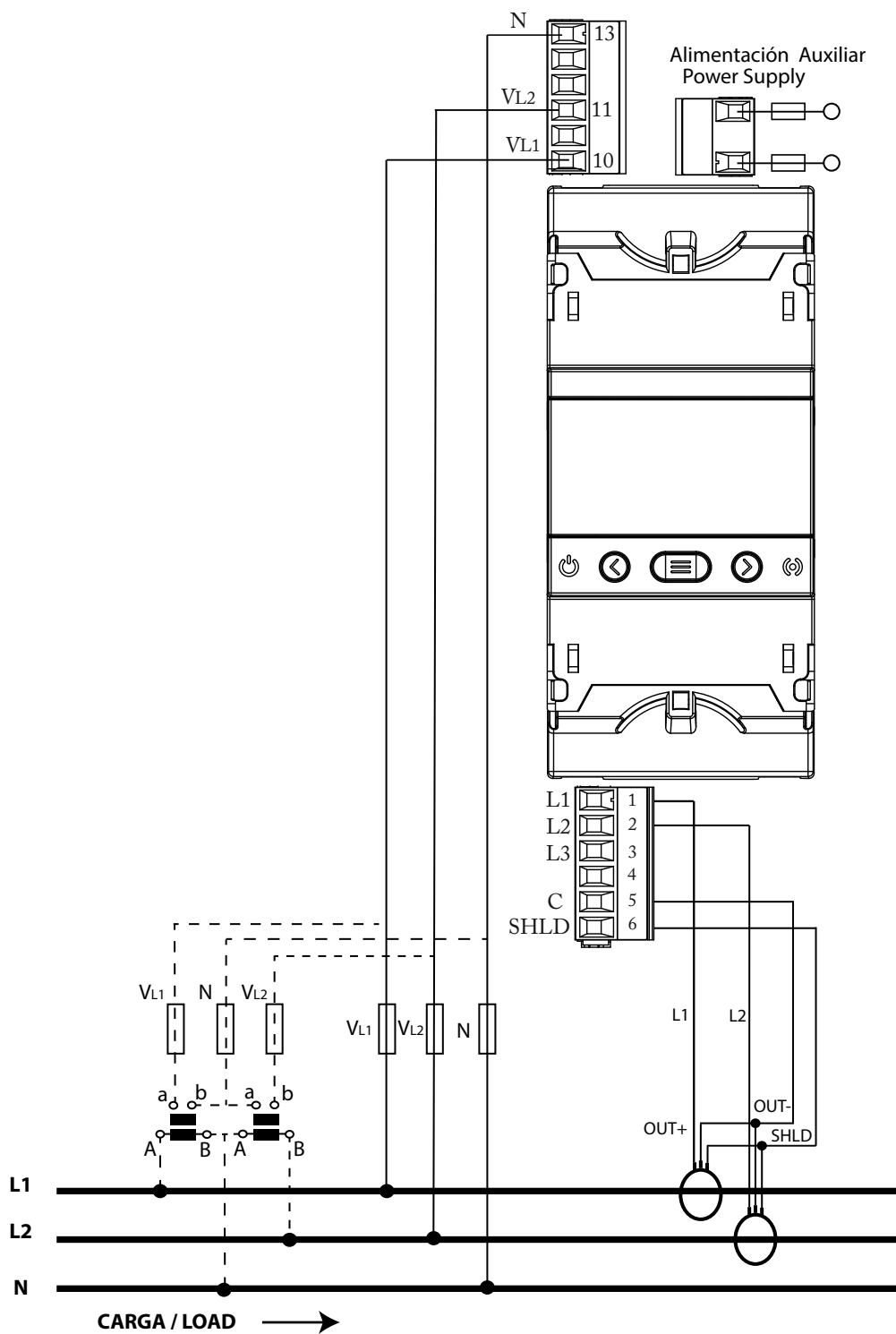

Figure 16: Measuring Two-Phase Networks with a 3-wire connection: CVM-E3-MINI-FLEX and CVM-E3-MINI-FLEX-WiEth.



It is mandatory connect the **SHLD** terminal of the probe.

3.6.12.- MEASURING SINGLE-PHASE NETWORKS, PHASE TO PHASE, WITH A 2-WIRE CONNECTION: CVM-E3-MINI-ITF AND CVM-E3-MINI-ITF-WiEth

Measurement system: 2-2Ph

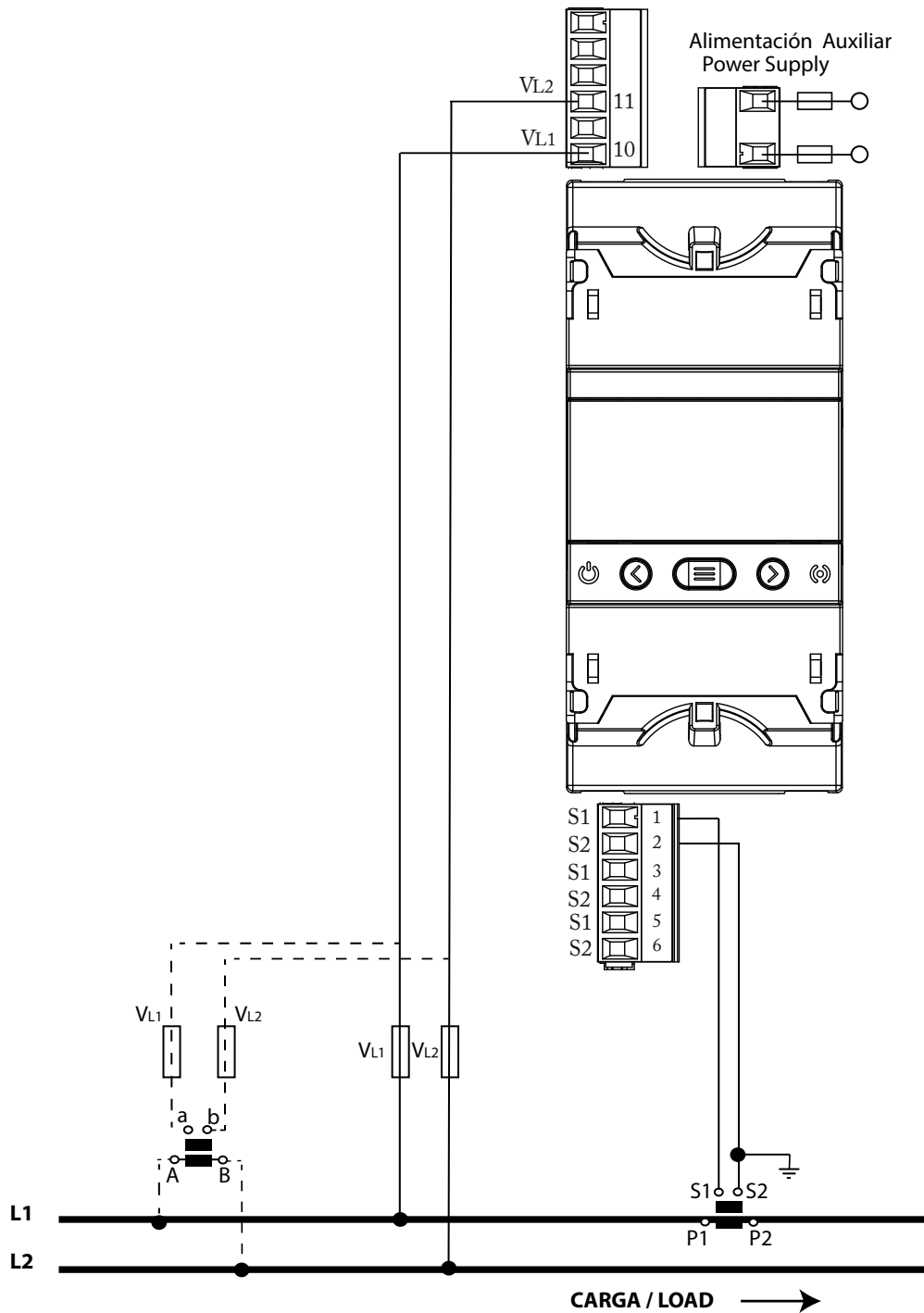



Figure 17: Measuring Single-Phase Networks, phase to phase, with a 2-wire connection: CVM-E3-MINI-ITF and CVM-E3-MINI-ITF-WiEth.

 To guarantee the insulation of the device and its category, it is necessary to earth the S2 terminals of the transformers.

3.6.14.- MEASURING SINGLE-PHASE NETWORKS, PHASE TO PHASE, WITH A 2-WIRE CONNECTION:
CVM-E3-MINI-FLEX AND CVM-E3-MINI-FLEX-WiEth

Measurement system: 2-2Ph

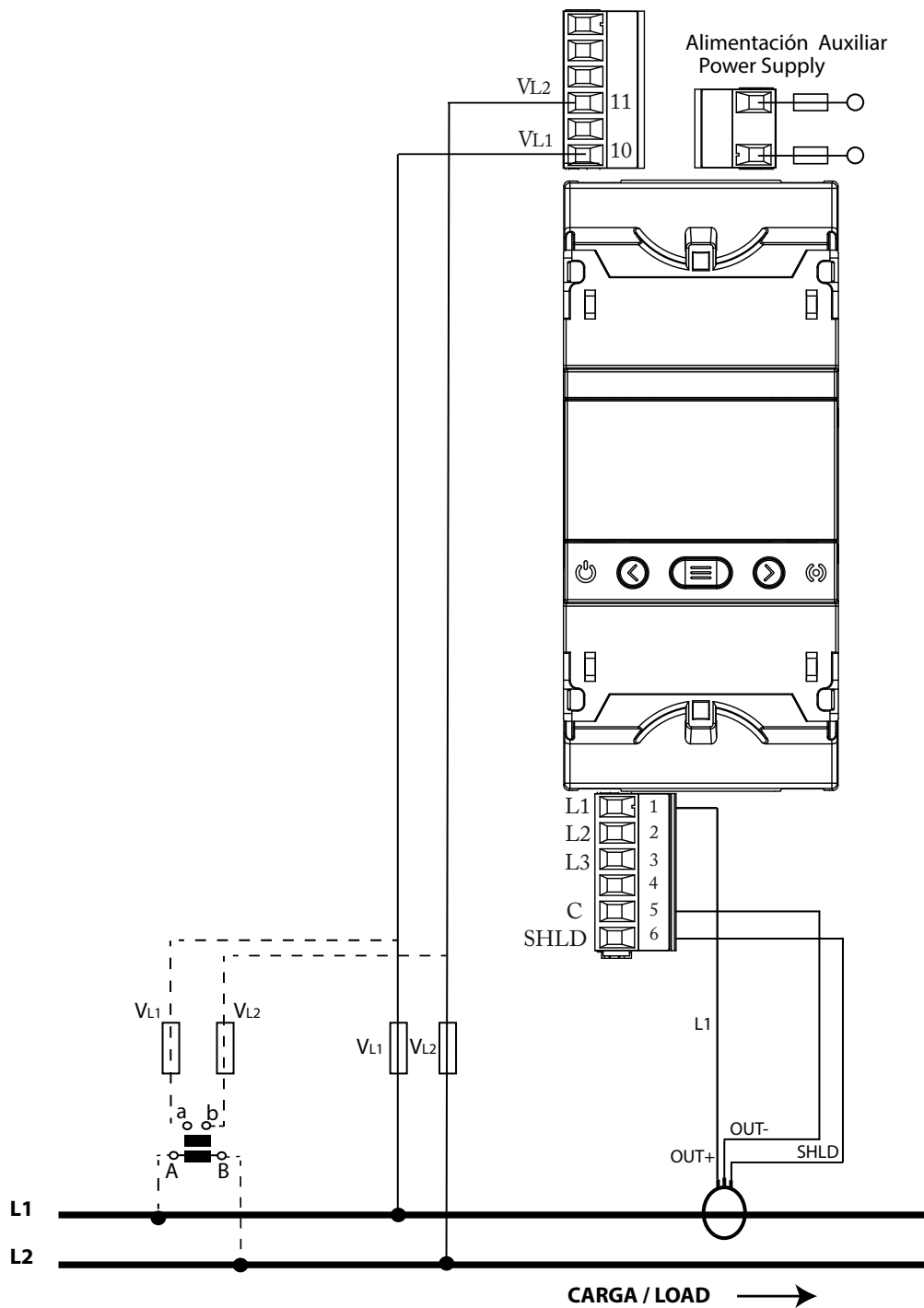

Figure 19: Measuring Single-Phase Networks, phase to phase, with a 2-wire connection: CVM-E3-MINI-FLEX and CVM-E3-MINI-FLEX-WiEth.



It is mandatory connect the SHLD terminal of the probe.

3.6.15.- MEASURING SINGLE-PHASE NETWORKS, PHASE TO NEUTRAL, WITH A 2-WIRE CONNECTION: CVM-E3-MINI-ITF AND CVM-E3-MINI-ITF-WiEth

Measurement system: 2- I_{Ph}

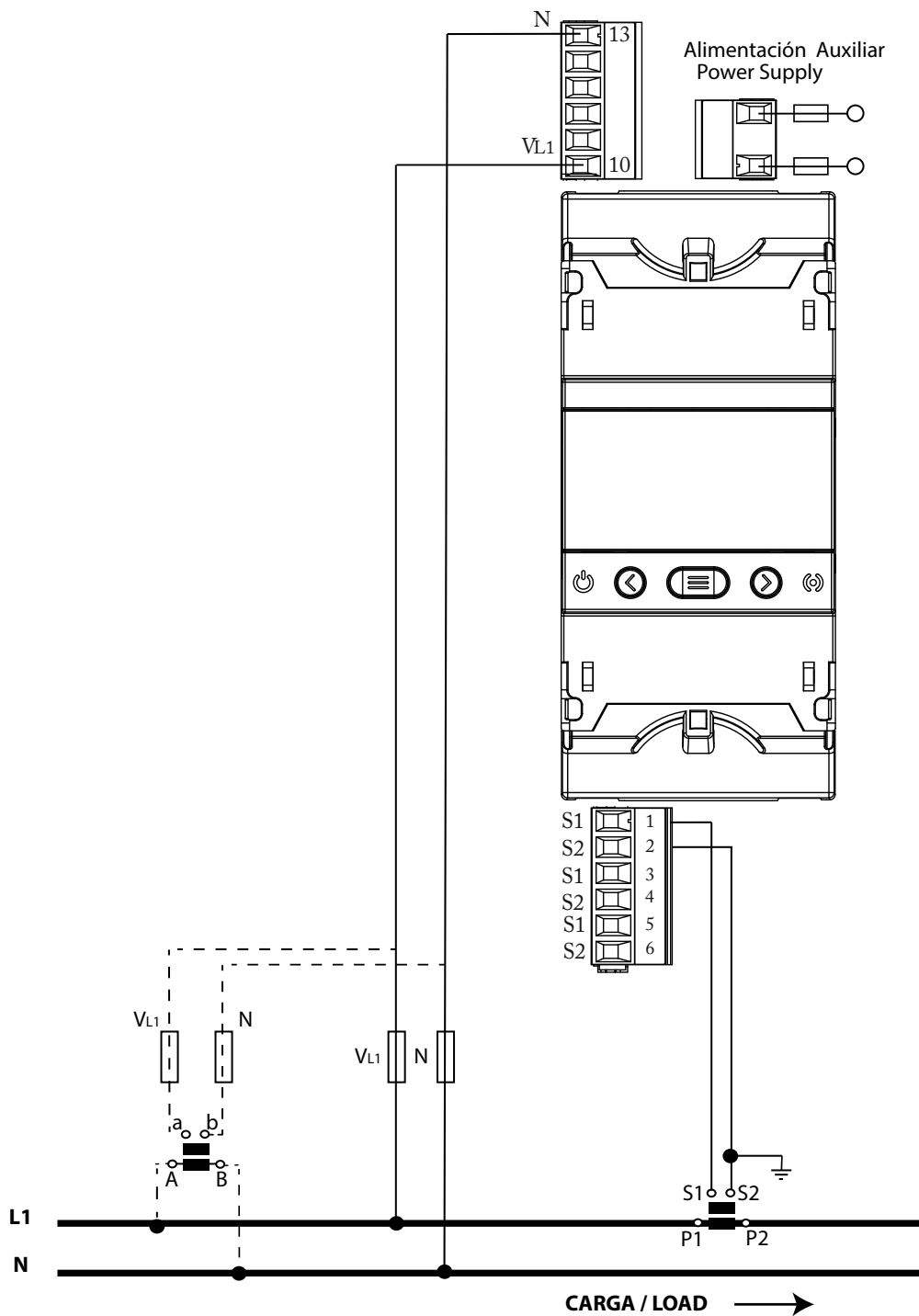

Figure 20: Measuring Single-Phase Networks, phase to neutral, with a 2-wire connection: CVM-E3-MINI-ITF and CVM-E3-MINI-ITF-WiEth.



To guarantee the insulation of the device and its category, it is necessary to earth the S2 terminals of the transformers.

3.6.16.- MEASURING SINGLE-PHASE NETWORKS, PHASE TO NEUTRAL, WITH A 2-WIRE CONNECTION: CVM-E3-MINI-MC AND CVM-E3-MINI-MC-WiEth

Measurement system: 2- IPh

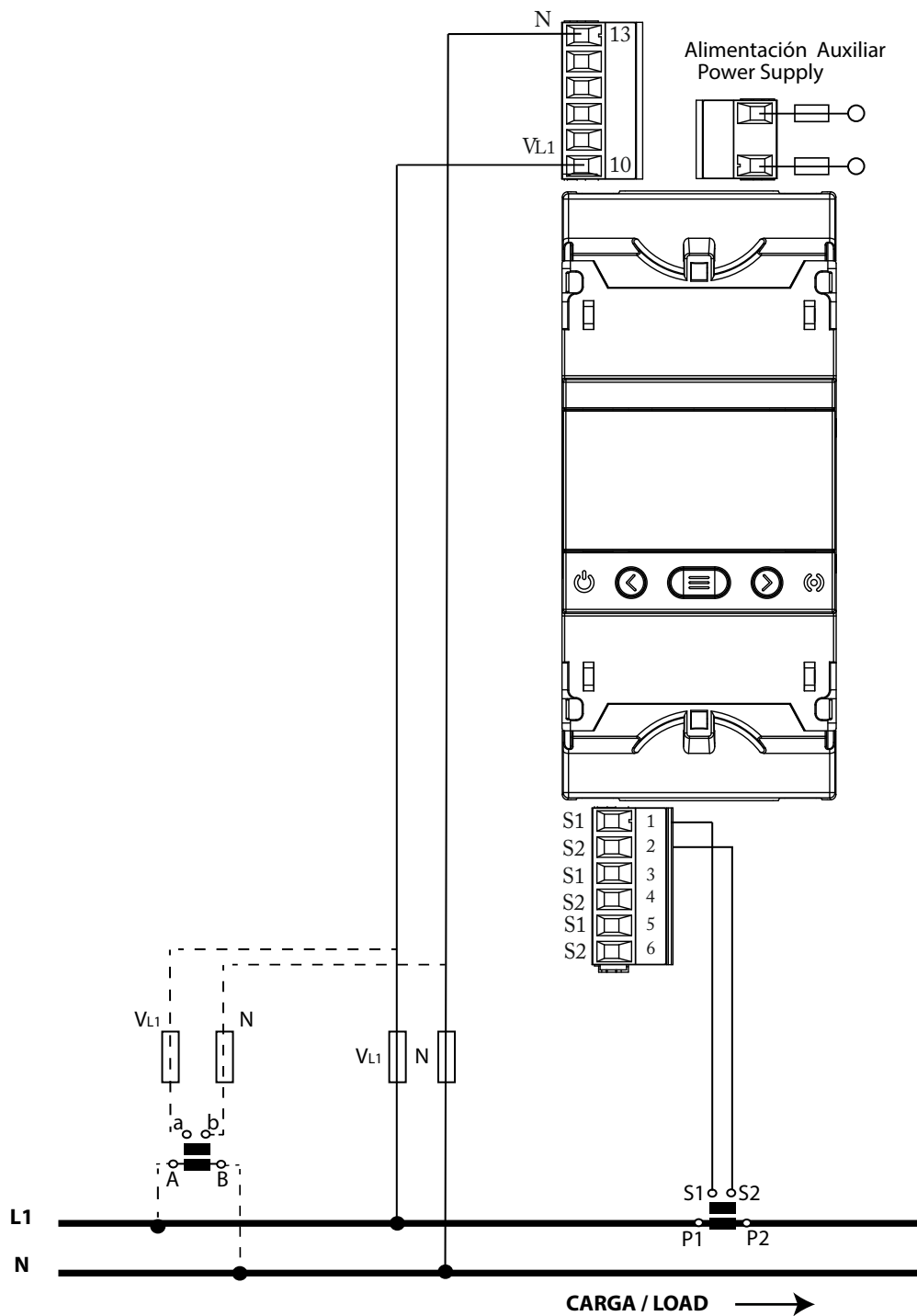

Figure 21: Measuring Single-Phase Networks, phase to neutral, with a 2-wire connection: CVM-E3-MINI-MC and CVM-E3-MINI-MC-WiEth.

Note: Do not connect MC current transformers to ground.



The MC transformer secondary value is set to 0.250 A (fixed value).

3.6.17.- MEASURING SINGLE-PHASE NETWORKS, PHASE TO NEUTRAL, WITH A 2-WIRE CONNECTION: CVM-E3-MINI-FLEX AND CVM-E3-MINI-FLEX-WiEth

Measurement system: 2- 1Ph

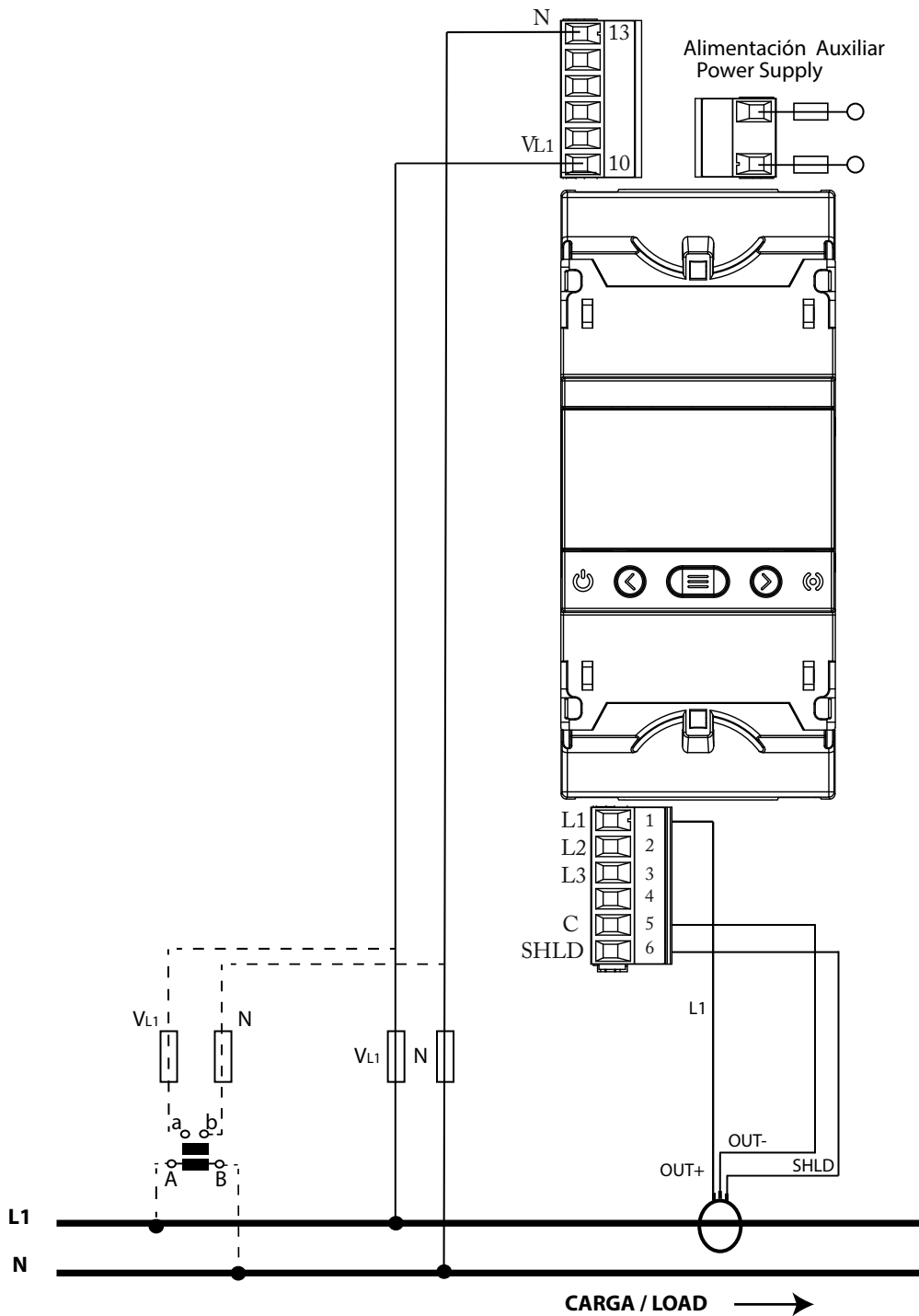

Figure 22: Measuring Single-Phase Networks, phase to neutral, with a 2-wire connection: CVM-E3-MINI-FLEX and CVM-E3-MINI-FLEX-WiEth.



It is mandatory connect the **SHLD** terminal of the probe.

4.- OPERATION

The CVM-E3-MINI is a four-quadrant power analyzer (consumption and generation). The device can operate according to three different measurement conventions:

- ✓ CIRCUTOR measurement convention.
- ✓ IEC measurement convention.
- ✓ IEEE measurement convention.

The measurement convention is configured in the setup menu, see "6.7. MEASUREMENT CONVENTION".

- ✓ CIRCUTOR. measurement convention

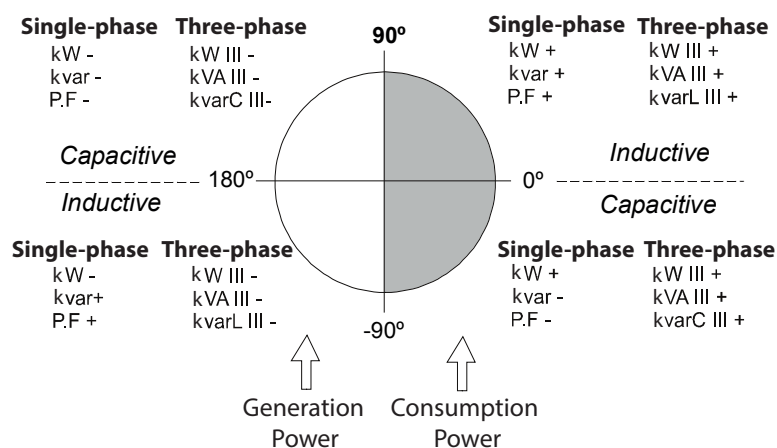

Figure 23: CIRCUTOR measurement convention.

- ✓ IEC measurement convention

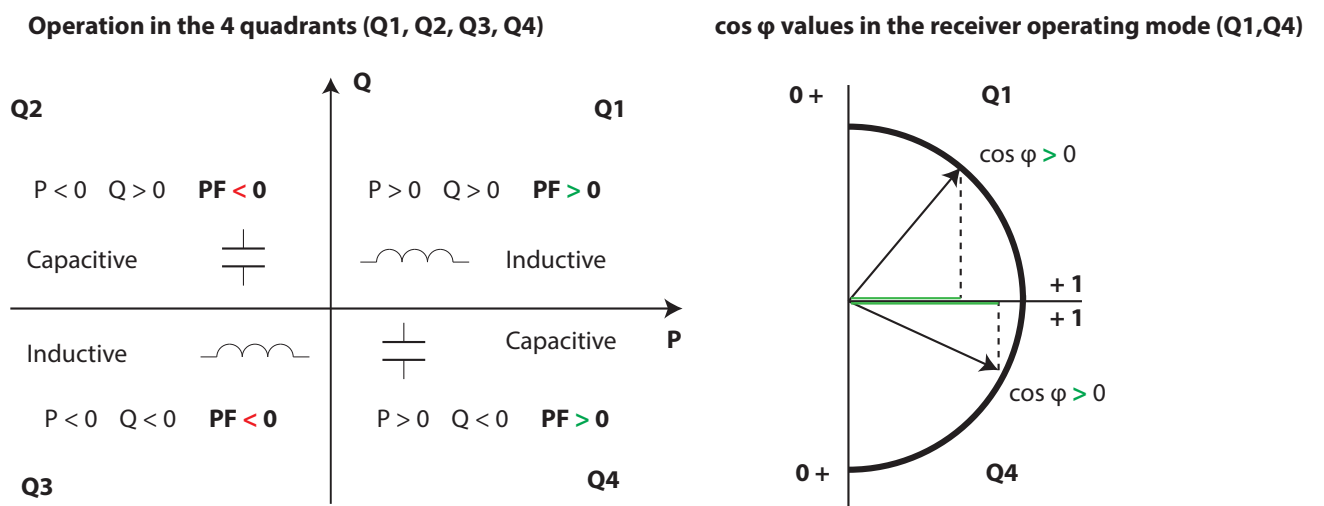

Figure 24: IEC measurement convention.

✓ IEEE measurement convention

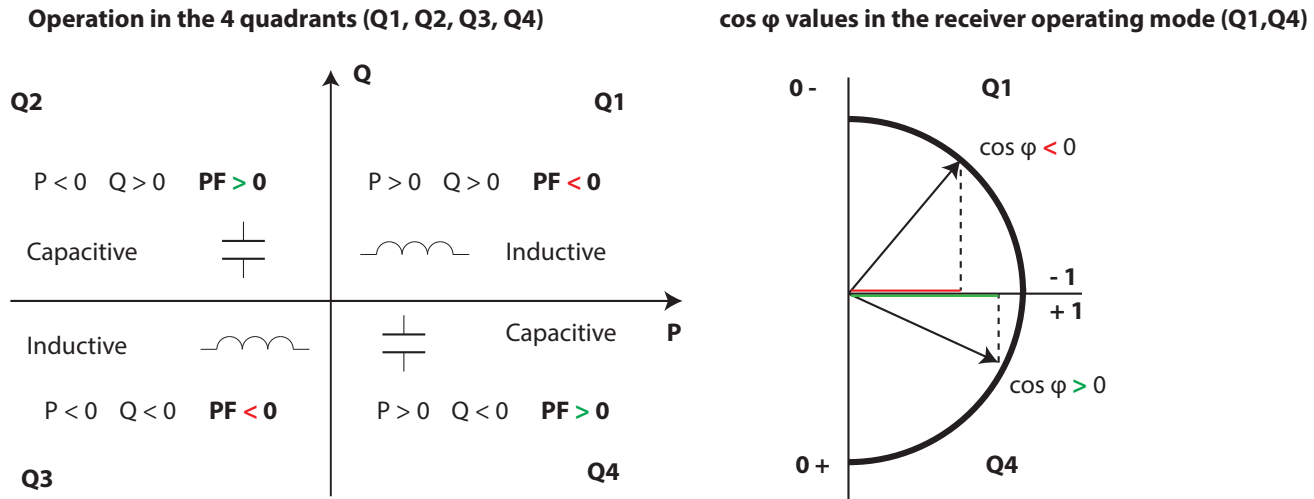

Figure 25: IEEE measurement convention.

4.1.- MEASURING PARAMETERS

The device displays the electrical parameters shown in Table 11.

Table 11: Measuring parameters of the CVM-E3-MINI

Parameter	Units	Phases L1-L2-L3	Total III	Maxim. value	Minim. value
Phase-neutral voltage	Vph-N	✓		✓	✓
Phase-phase voltage	Vph-ph	✓	✓	✓	✓
Current	A	✓	✓	✓	✓
Neutral Current ⁽¹⁾	A	✓	✓	✓	✓
Frequency	Hz	✓	✓	✓	✓
Active power	M/kW	✓	✓	✓	✓
Apparent power	M/kVA	✓	✓	✓	✓
Total Reactive Power	M/kvar	✓	✓	✓	✓
Total Reactive Power - Consumption	M/kvar	✓	✓	✓	✓
Total Reactive Power - Generation	M/kvar	✓	✓	✓	✓
Total Inductive Reactive Power	M/kvarL	✓	✓	✓	✓
Inductive Reactive Power - Consumption	M/kvarL	✓	✓	✓	✓
Inductive Reactive Power - Generation	M/kvarL	✓	✓	✓	✓
Total Capacitive Reactive Power	M/kvarC	✓	✓	✓	✓
Capacitive Reactive Power - Consumption	M/kvarC	✓	✓	✓	✓
Capacitive Reactive Power - Generation	M/kvarC	✓	✓	✓	✓
Power factor	PF	✓	✓	✓	✓
Cos φ	φ	✓	✓	✓	✓
THD % Voltage	% THD V	✓		✓	✓
THD % Current	% THD A	✓		✓	✓

Table 11 (Continuation): Measuring parameters of the CVM-E3-MINI.

Parameter	Units	Phases L1-L2-L3	Total III	Maxim. value	Minim. value
Harmonic Breakdown - Voltage (up to the 31st order harmonic)	harm V	✓			
Harmonic Breakdown - Current (up to the 31st order harmonic)	harm V	✓			
Total Active Energy (Consumption and Generation)	M/kWh	✓ ⁽¹⁾	✓		
Total Inductive Reactive Energy (Consumption and Generation)	M/kvarLh	✓ ⁽¹⁾	✓		
Total Capacitive Reactive Energy (Consumption and Generation)	M/kvarCh		✓		
Total Apparent Energy (Consumption and Generation)	M/kVAh		✓		
Active Energy Tariff 1 (Consumption and Generation)	M/kWh	✓ ⁽¹⁾	✓		
Inductive Reactive Energy Tariff 1 (Consumption and Generation)	M/kvarLh	✓ ⁽¹⁾	✓		
Capacitive Reactive Energy Tariff 1 (Consumption and Generation)	M/kvarCh		✓		
Apparent Energy Tariff 1 (Consumption and Generation)	M/kVAh		✓		
Active Energy Tariff 2 (Consumption and Generation)	M/kWh	✓ ⁽¹⁾	✓		
Inductive Reactive Energy Tariff 2 (Consumption and Generation)	M/kvarLh	✓ ⁽¹⁾	✓		
Capacitive Reactive Energy Tariff 2 (Consumption and Generation)	M/kvarCh		✓		
Apparent Energy Tariff 2 (Consumption and Generation)	M/kVAh		✓		
Maximum Current Demand	A	✓		✓	
Maximum Demand of Active power	M/kW		✓	✓	
Maximum Demand of Apparent Power	M/kVA		✓	✓	
Maximum Demand of Inductive Power	M/kvarL		✓	✓	
Maximum Demand of Capacitive Power	M/kvarC		✓	✓	
Parameter	Units	Tariff: T1-T2		Total	
No. of hours	hours	✓		✓	
Cost	COST	✓		✓	
CO ₂ Emissions	kgCO ₂	✓		✓	







⁽¹⁾ These variables are only displayed through communications, see **Table 67**.

4.2.- KEYBOARD FUNCTIONS

The **CVM-E3-MINI** has 3 keys that allow you to browse between the various screens and program the device.

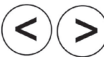

Key functions on measuring screens (**Table 12**):

Table 12: Key functions on measuring screens.

Key	Short keystroke	Long keystroke (2 s)
	Previous screen	Display of minimum value
	Next screen	Display of maximum value
	Browsing the different profiles (analyzer, e3)	Accessing the programming menu
		Display of the Maximum Demand
		Unlocks the active alarm
		Models CVM-E3-MINI-xxx : Visualization of the status of the digital input and output. Models CVM-E3-MINI-xxx-WiEth : Display of the Ethernet, Wi-Fi and Bluetooth® communications screens.
		Display of device information screens.



Key functions on harmonics screens (**Table 13**):

Table 13: Key functions on harmonics screens.

Key	Short keystroke	Long keystroke (2 s)
	Output of the harmonics screens	
	Next screen	
	Browsing the different types of harmonics	Accessing the programming menu



Key functions on the programming menu, query mode (**Table 14**):

Table 14: Key functions on the programming menu, query mode.

Key	Short keystroke	Long keystroke (2 s)
	Previous screen	Programming output
	Next screen	Programming output
		Entering and exiting the edit mode of the programming menu

Key functions on the programming menu, edit mode (Table 15):

Table 15: Key functions on the programming menu, edit mode.

Key	Keystroke
	Skips to the previous digit that can be edited (flashing)
	Increases the digits (0-9) or rotates between the different options.
	Skips to the next digit that can be edited (flashing)

4.3.- DISPLAY

The device has a backlit LCD display showing all the parameters listed in Table 11. The display is divided into two areas (Figure 26):

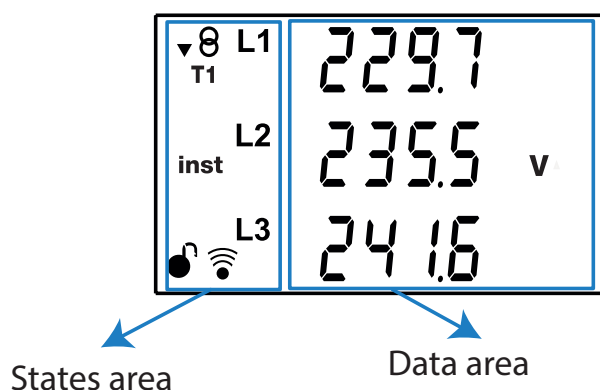





Figure 26: CVM-E3-MINI Display areas

- ✓ The **data** area displays the values measured or calculated by the device.
- ✓ The device **states** area shows the different states, profiles and information about the unit (Table 16).

Table 16: Icons in the display.

Icon	Description	Icon	Description
	Facility status: ▼ Facility consuming. ▲ Facility generating.	inst	Instantaneous value
e³	Operation profile e ³	min	Minimum value
T12	Tariff : T1 Tariff 1, T2 Tariff 2	prog	Programming screen
dem	Maximum demand value		Programming menu: 🔒 Locked with a password. 🔓 Unlocked.
max	Maximum value		Communications activated

4.4.- LED INDICATORS

The **CVM-E3-MINI** device has 2 LEDs:

- **CPU**, indicates that the device is on, flashing each second.
- **ALARM / ENERGY PULSES**; if this is on, it indicates that an alarm or an energy pulses output has been activated. In the case of the energy pulses, the LED will be lit and flash with the rate of these pulses.

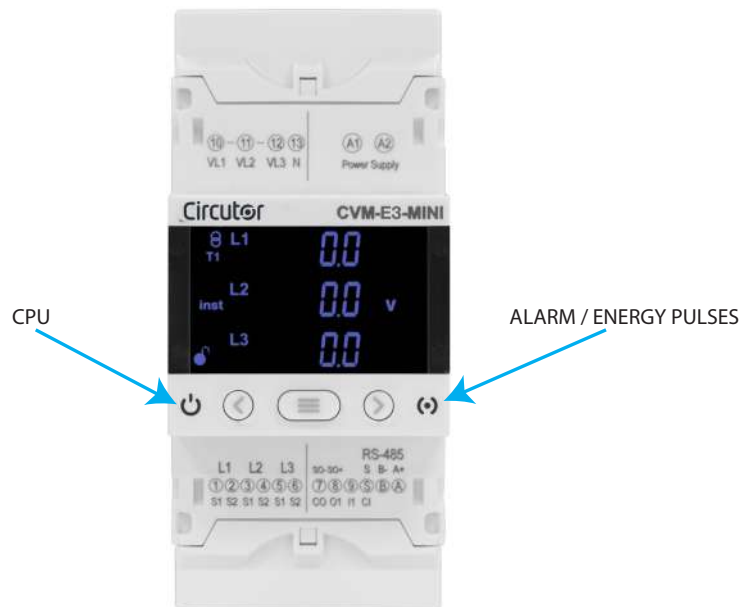

Figure 27: LED Indicators of the CVM-E3-MINI.



4.5.- DIGITAL INPUT (Models CVM-E3-MINI-xxx)

The **CVM-E3-MINI-xxx** has one digital input (terminals **S** and **9** on **Figure 4**) that can be programmed to operate as a logic input, tariff selection or pulse counter.

The operation of the input as a pulse counter is independent of the programming of the digital input, that is, the device can be used as a logic input or tariff selection at the same time as a pulse counter.

The configuration of the digital input as pulse counter can only be done by communications, see "7.3.8.12. Digital input (Models CVM-E3-MINI-xxx)".

If configured as a logic input, the device displays the status of that input. See "6.19. OPERATING MODE OF DIGITAL INPUT (Models CVM-E3-MINI-xxx)".

Press the   keys to access the digital input status screen, see "5.4.- DIGITAL INPUT AND OUTPUT STATUS SCREEN (Models CVM-E3-MINI-xxx)".

The selected tariff can be determined in accordance with the status of the inputs, as shown in **Table 17**.



Table 17: Selecting the tariff in accordance with the input status.

IN1, Input 1		Tariff
Logic input	Tariff selection	
x		T1
	0	T1
	1	T2

Note: In the *CVM-E3-MINI-xxx-WiEth* models, the tariff is selected in the settings menu.

4.6.- DIGITAL OUTPUT (Models CVM-E3-MINI-xxx)

The device has one digital output, optoisolated NPN transistors (terminals 8 and 7 on **Figure 4**), fully programmable, see **"6.18. PROGRAMMING ALARM : DIGITAL OUTPUT T1"**.

Press the   keys to access the digital output status screen, see **"5.4.- DIGITAL INPUT AND OUTPUT STATUS SCREEN (Models CVM-E3-MINI-xxx)"**.

5.- DISPLAY

The **CVM-E3-MINI** has 2 operation profiles. The display screens will be opened for the corresponding profile:

- ✓ Analyzer profile, **analyzer**,
- ✓ Electrical energy efficiency profile, **e³**,

By default, the device displays the electrical energy efficiency profile, **e³**, press the  key to change from one operating profile to another.

5.1.- ANALYZER PROFILE

The device displays 15 different screens for the **analyzer** profile (Table 18) and the voltage and current harmonics, up to the 31st order harmonic, for each one of the lines, L1, L2 and L3. ("**5.1.4.- HARMONICS**").

Use keys  and  to browse the different screens.

The **inst** symbol on the left of the screen indicates that the values being displayed are of the instantaneous type.

Table 18: Analyzer profile screens.

Screen	Parameters (units)
	phase-neutral Voltage L1 (V^{ph-N}) phase-neutral Voltage L2 (V^{ph-N}) phase-neutral Voltage L3 (V^{ph-N})
	phase-phase Voltage L1-L2 (V^{ph-ph}) phase-neutral Voltage L2-L3 (V^{ph-ph}) phase-neutral Voltage L3-L1 (V^{ph-ph})
	Medium phase-neutral Voltage Medium phase-phase Voltage Frequency (Hz)

Table 18 (Continuation): Analyzer profile screens.

Screen	Parameters (units)
 <p> L1 526.3 inst L2 47.82 A L3 42.51 </p>	Current L1 (A) Current L2 (A) Current L3 (A)
 <p> L1 11.54 kW inst L2 10.93 L3 9.26 </p>	Active Power L1 (M/kW) Active Power L2 (M/kW) Active Power L3 (M/kW)
 <p> L1 12.09 inst L2 11.28 kVA L3 10.30 </p>	Apparent Power L1 (M/kVA) Apparent Power L2 (M/kVA) Apparent Power L3 (M/kVA)
 <p> L1 3.73 inst L2 0.00 L3 4.40 kvar^L </p>	Inductive Reactive Power L1 (M/kvar ^L) Inductive Reactive Power L2 (M/kvar ^L) Inductive Reactive Power L3 (M/kvar ^L)
 <p> L1 0.00 inst L2 2.73 L3 0.00 kvar_c </p>	Capacitive Reactive Power L1 (M/kvar _c) Capacitive Reactive Power L2 (M/kvar _c) Capacitive Reactive Power L3 (M/kvar _c)
 <p> L1 31.74 kW^{III} inst L2 33.42 kVA L3 8.30 kvar^L </p>	Active Power III (M/kW) Apparent Power III (M/kVA) Inductive Reactive Power III (M/kvar ^L)

Table 18 (Continuation): Analyzer profile screens.

Screen	Parameters (units)
	Active Power III (M/kW) Apparent Power III (M/kVA) Capacitive Reactive Power III (M/kvar _c)
	Cos ϕ L1 (cos ϕ) Cos ϕ L2 (cos ϕ) Cos ϕ L3 (cos ϕ)
	Power factor L1 (PF) Power factor L2 (PF) Power factor L3 (PF)
	Power factor III (PF) Cos ϕ III (cos ϕ)
	THD % Voltage L1 (V THD %) THD % Voltage L2 (V THD %) THD % Voltage L3 (V THD %)
	THD % Current L1 (A THD %) THD % Current L2 (A THD %) THD % Current L3 (A THD %)

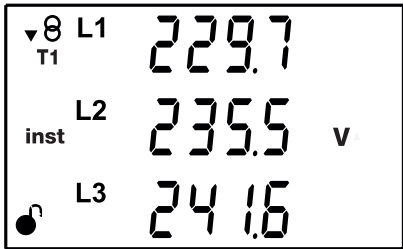
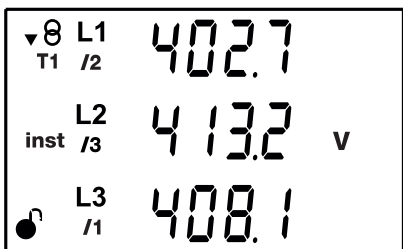
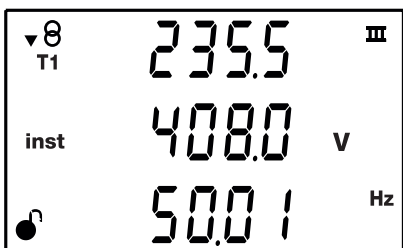
Also displayed on these screens are:

- ✓ Maximum values
- ✓ Minimum values
- ✓ Maximum Demand
- ✓ Harmonics

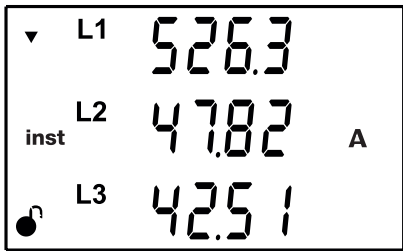
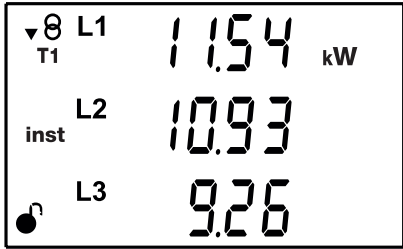
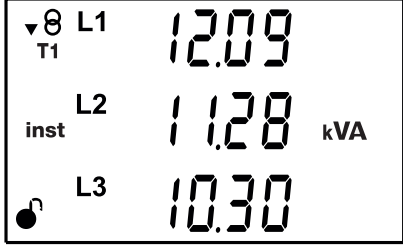
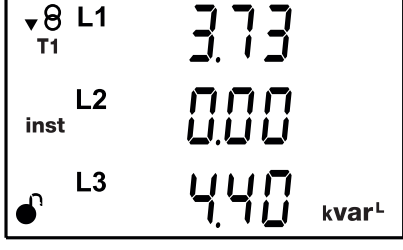
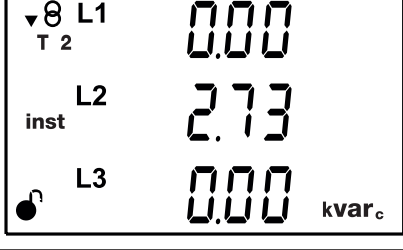
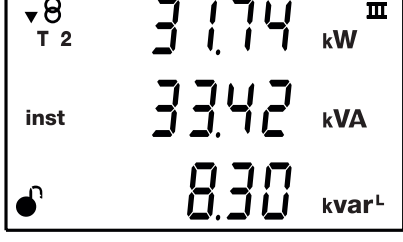
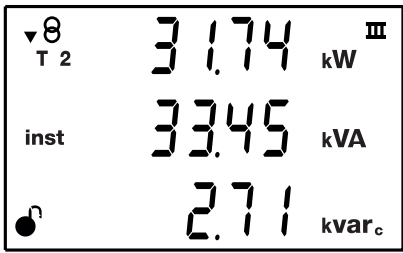
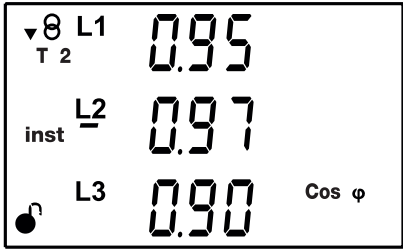
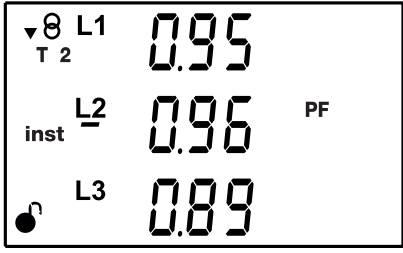
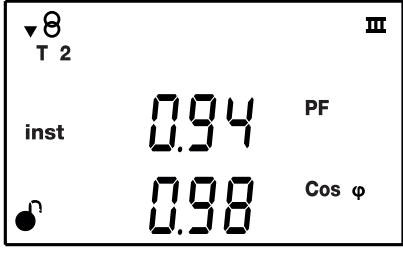
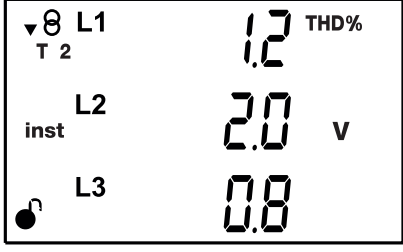
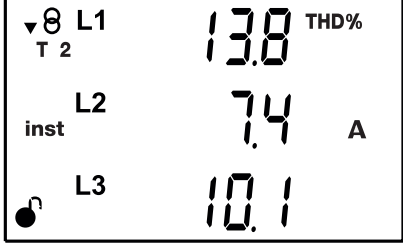
5.1.1.- MAXIMUM VALUES

To see the maximum values of the screen being displayed, press the  key for 2 seconds. These are displayed for 10 seconds.

Press the  and  keys to display all other maximum values.

The **max** symbol is shown on the display.

The maximum and minimum values are reset on the programming menu. ("**6.10.- DELETING MAXIMUM AND MINIMUM VALUES**").

5.1.2.- MINIMUM VALUES

To see the minimum values of the screen being displayed, press the  key for 2 seconds. These are displayed for 30 seconds.

Press the  and  keys to display all other maximum values.



The **min** symbol is shown on the display.

The maximum and minimum values are reset on the programming menu. ("**6.10.- DELETING MAXIMUM AND MINIMUM VALUES**").

5.1.3.- MAXIMUM DEMAND

The device calculates the maximum demand of the following:

- ✓The Current of each phase.
- ✓Three-Phase Active Power.
- ✓Three-Phase Apparent Power.
- ✓Three-Phase inductive Power.
- ✓ Three-Phase capacitive Power.

This value can be displayed on the display screen of the parameter by pressing the  and  keys at the same time.

The **dem** symbol appears on the display.

Press keys  or  to stop displaying the maximum demand values.

The maximum demand values are reset on the programming menu: "**6.10.- DELETING MAXIMUM DEMAND**".

5.1.4.- HARMONICS

The device can display the voltage and current harmonics, up to the 31st order harmonic, for each one of the lines, L1, L2 and L3.

Harmonics display is disabled by defect; see "**6.13.- ENABLE HARMONICS DISPLAY SCREEN**" to enable display.

A minimum signal level is required to measure harmonics correctly, i.e., a signal level of at least 20 V is

required to measure the voltage harmonics and of at least 200 mA to measure the current harmonics. If the levels are lower, the unit will not calculate them and will display a value of 0.

The harmonics display screens can be displayed by pressing the  key shown after the last profile screen.

Harmonics are represented as shown in **Figure 28**. The figure shows the 15th voltage harmonic (H15).

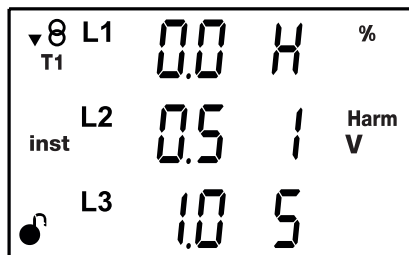



Figure 28: 15th voltage harmonic.

The  key jumps to the next harmonics screen.

Press the  key to jump from the voltage harmonics to the current harmonics, and from the current harmonics to the home screen of the instantaneous values.

5.1.5.- DETECTION OF INCORRECT CONNECTION AND INCORRECT DIRECTION OF ROTATION

✓ Incorrect connection or disconnection

The device has a system for detecting the incorrect connection or disconnection of the voltage lines. If this error occurs, the device displays **0** on the lines with a voltage value of less than 50% of the line with the highest voltage value.

✓ Incorrect direction of rotation

The device has a system for detecting the incorrect direction of rotation of the voltages. In other words, if each of the voltages has been correctly connected to the appropriate terminal, L1 to terminal 10, L2 to terminal 11 and L3 to terminal 12.

If there is an error in the direction of rotation, the icons **L1**, **L2** and **L3** flash on the display.

The device has a RS-485 communications parameter, which indicates whether an incorrect direction of rotation has been detected ("**7.3.6. DETECTION OF INCORRECT DIRECTION OF ROTATION**").

Note: The detection of the direction of rotation is only enabled for measurement systems: Three-phase network measurement (4-ЭРн, Э-ЭРн y Э-Р-0н) and two-phase network measurement with 3-wire connection (Э-2Рн).

5.2.- e³ PROFILE

The installation's consumed and generated energy are displayed on the e³ profile of the device. The installation status is also displayed:

- ▼⊗ Installation is consuming energy.
- ▲⊗ Installation is generating energy.

Long press (3 sec.) the > or < keys to jump from the generated values to the consumed values displayed.

The generation values are identified with the negative sign on the screen, which appears in front of each parameter.

Note: If the 2 quadrant option has been configured, only the consumed values can be displayed.

This profile is identified with the e³ symbol on the left of the screen.

Use keys < and > to browse the different screens (short keystroke).

Table 19: Screens of the e³ profile.

Screen	Parameters (units)
	Total three-phase active Energy ⁽²⁾⁽³⁾ (kWh)
	Total three-phase Apparent Energy ⁽²⁾⁽³⁾ (kVAh)
	Total three-phase Inductive Reactive Energy ⁽²⁾⁽³⁾ (kvar ^L h)
	Total three-phase Capacitive Reactive Energy ⁽²⁾⁽³⁾ (kvar _c h)

Table 19 (Continuation): Screens of the e³ profile.



Screen	Parameters (units)
	Total Cost ⁽²⁾ (cost)
	Total CO ₂ Emissions ⁽²⁾ (kgCO ₂)
	Total No. of hours ⁽²⁾ (hours)
	Three-phase Active Energy Tariff 1 ⁽³⁾ (kWh)
	Three-phase Apparent Energy Tariff 1 ⁽³⁾ (kVAh)
	Three-phase Inductive Reactive Energy Tariff 1 ⁽³⁾ (kvar ^h)

Table 19 (Continuation): Screens of the e³ profile.

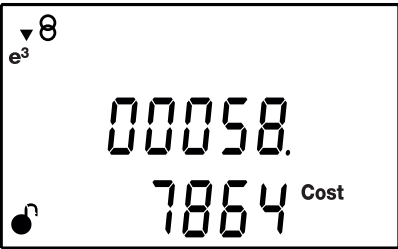

Screen	Parameters (units)
 <p>▼ 8 e³ T1 000000 III 00116. 910 Mkvar_c.h</p>	<p>Three-phase Capacitive Reactive Energy Tariff 1⁽³⁾ (kvar_c.h)</p>
 <p>▼ 8 e³ T1 00050. 1061 Cost</p>	<p>Cost Tariff 1 (cost)</p>
 <p>▼ 8 e³ T1 00111. 5720 kgCO₂</p>	<p>CO₂ Emissions Tariff 1 (kgCO₂)</p>
 <p>▼ 8 e³ T1 0513.5 Hours</p>	<p>No. of hours Tariff 1 (hours)</p>
 <p>▼ 8 e³ T 2 000000 kWh III 05170. 645</p>	<p>Three-phase Active Energy Tariff 2⁽³⁾ (kWh)</p>
 <p>▼ 8 e³ T 2 000000 kWh III 01610. kVAh 571</p>	<p>Three-phase Apparent Energy Tariff 2⁽³⁾ (kVAh)</p>

Table 19 (Continuation): Screens of the e³ profile.

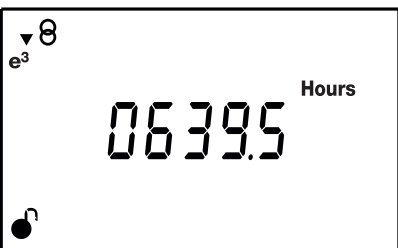
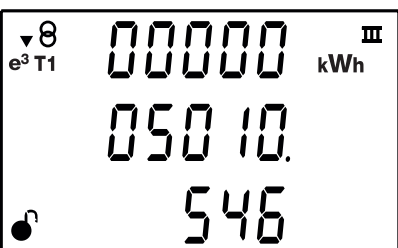
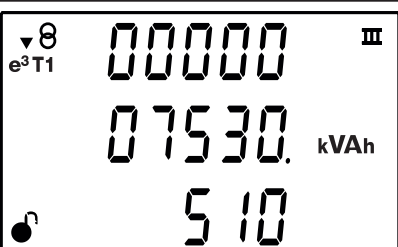
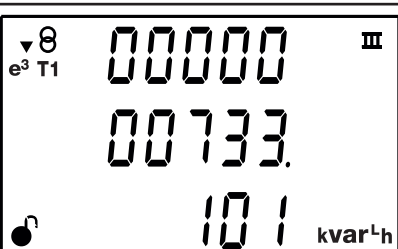
Screen	Parameters (units)
<p> ∇III $e^3 T 2$ 000000 00733. 411 kvar^h </p>	Three-phase Inductive Reactive Energy Tariff 2 ⁽³⁾ (kvar ^h)
<p> ∇III $e^3 T 2$ 000000 00416. 333 Mkvar_ch </p>	Three-phase Capacitive Reactive Energy Tariff 2 ⁽³⁾ (kvar _c h)
<p> ∇III $e^3 T 2$ 00052. 7064 Cost </p>	Cost Tariff 2 (cost)
<p> ∇III $e^3 T 2$ 00117. kgCO₂ 5123 </p>	CO ₂ Emissions Tariff 2 (kgCO ₂)
<p> ∇III $e^3 T 2$ 06135 Hours </p>	No. of hours Tariff 2 (hours)

⁽²⁾ Total = Tariff 1 + Tariff 2.

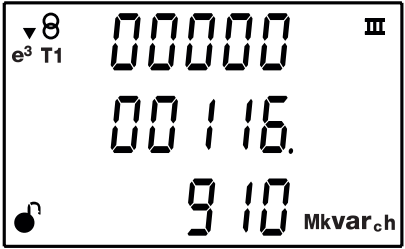
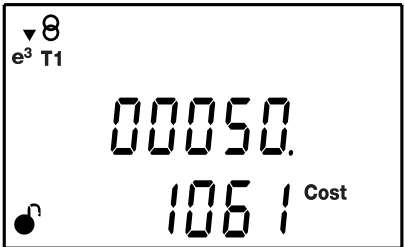

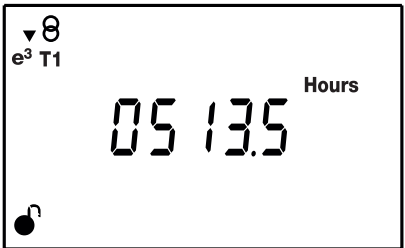
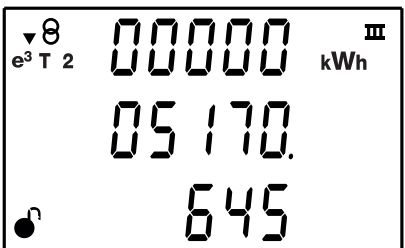
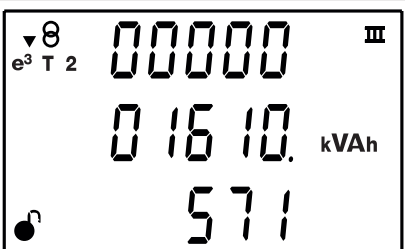
⁽³⁾ The maximum displayed energy value is 999999999.999 k.

Symbols T1 and T2 on the display indicate the two tariffs available on the device.

The symbol will flash if the current tariff is displayed.

If the Total tariff is displayed (= Tariff 1 + Tariff 2), symbols T1 and T2 will remain disabled.

5.3.- DEVICE INFORMATION SCREENS

Press the    keys at the same time on any display screen to open the device information screens, with the version and serial number of the device (Figure 29).

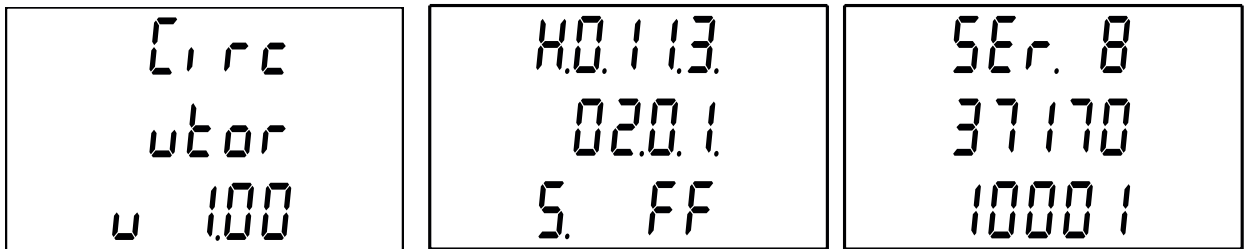



Figure 29: Device information screens.

5.4.- DIGITAL INPUT AND OUTPUT STATUS SCREEN (Models CVM-E3-MINI-xxx)

Press the   keys at the same time on any display screen to show the status of the device's digital inputs and outputs (Figure 30).

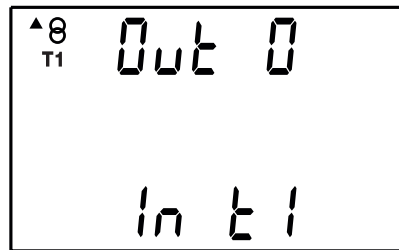

Figure 30: Digital input and output status screen.

The *Out* parameter indicates the status of the digital output: **0**: Output not activated
1: Output activated.



The *In* parameter indicates the status of the digital input.

If it has been configured as a logical input: **0**: Input not activated
1: Input activated.

If it has been configured as a tariff selection: **T1**: Tariff 1 selected.
T2: Tariff 2 selected.

5.5.- ETHERNET - Wi-Fi - Bluetooth® COMMUNICATIONS SCREENS (Models CVM-E3-MINI-xxx-WiEth)

Note: "ANNEX A - CONFIGURATION MENUS" shows the full settings tree structure.

Press the   keys simultaneously from any display screen to show the settings and display screens for Ethernet, Wi-Fi and Bluetooth® communications.

5.5.1. ETHERNET COMMUNICATIONS: DHCP CONFIGURATION

You can enable or disable DHCP on this screen. If DHCP is enabled (default configuration), the IP address is assigned dynamically via a central server. No other parameters need to be set up.

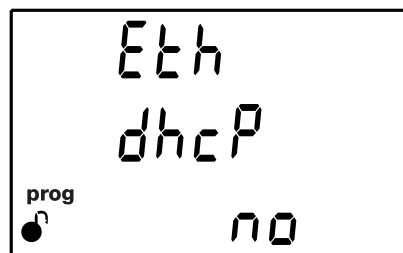



Press the  key for 3 seconds to enter the edit mode. The **prog** icon will flash on the left of the screen.

The  key is used to browse the different options:

✓ Configuration values

Table 20: Configuration values: DHCP Configuration.

	DHCP Configuration	
Possible values	no	DHCP is not enabled.
	YES	DHCP is enabled

To validate the value, press the  key for 3 seconds; the **prog** icon will stop flashing. Press key  to access the next programming step.

5.5.2. ETHERNET COMMUNICATIONS: IP ADDRESS

You can set up (DHCP disabled) or view the IP address on this screen.

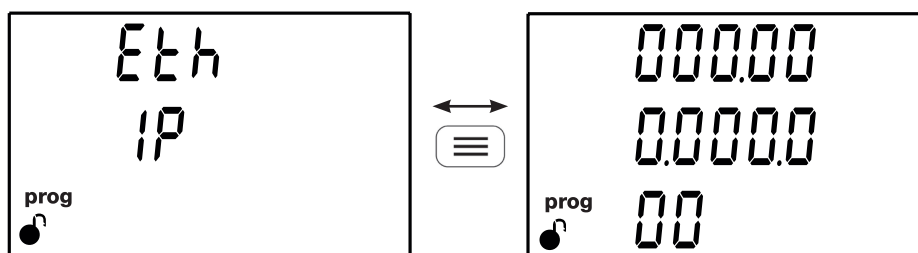

Press the key  to display the value.

Press the  key for 3 seconds to enter the edit mode. The **prog** icon will flash on the left of the screen.

Press the  key to modify the value of the flashing digit.

When the desired value is shown on the screen, use the  and  keys to move the edit cursor

To validate the value, press the  key for 3 seconds; the **prog** icon will stop flashing.

Press the  key to return to the initial IP address screen.

To access the following communications screen press the key .

5.5.3. ETHERNET COMMUNICATIONS: IP MASK

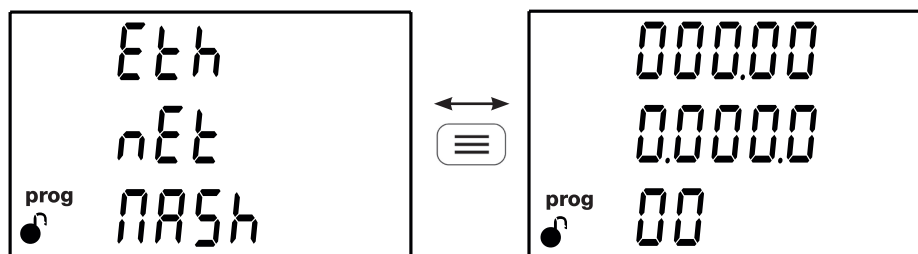

You can set up (DHCP disabled) or view the IP mask on this screen.



Press the key  to display the value.

Press the  key for 3 seconds to enter the edit mode. The **prog** icon will flash on the left of the screen.

Press the  key to modify the value of the flashing digit.

When the desired value is shown on the screen, use the  and  keys to move the edit cursor

To validate the value, press the  key for 3 seconds; the **prog** icon will stop flashing.

Press the  key to return to the initial IP mask screen.

To access the following communications screen press the key .

5.5.4. ETHERNET COMMUNICATIONS: GATEWAY

You can set up (DHCP disabled) or view the gateway for Ethernet communications on this screen.

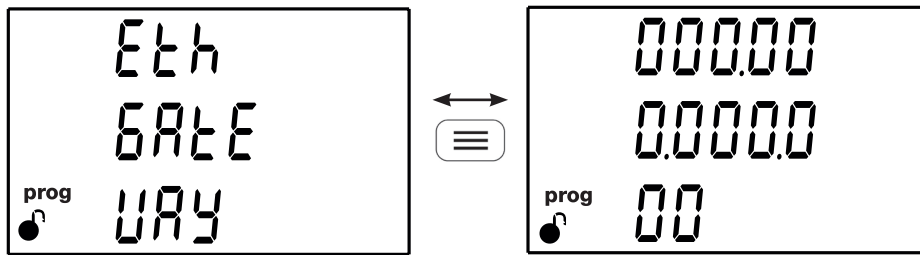

Press the key  to display the value.

Press the  key for 3 seconds to enter the edit mode. The **prog** icon will flash on the left of the screen.

Press the  key to modify the value of the flashing digit.

When the desired value is shown on the screen, use the  and  keys to move the edit cursor

To validate the value, press the  key for 3 seconds; the **prog** icon will stop flashing.

Press the  key to return to the initial gateway screen.

To access the following communications screen press the key .

5.5.5. ETHERNET COMMUNICATIONS: MAC ADDRESS

This screen shows the device's MAC address.

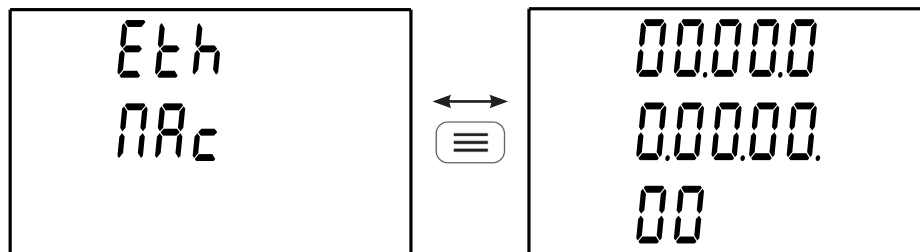

Press the key  to display the value.

To access the following communications screen press the key .

5.5.6. WI-FI COMMUNICATIONS: IP ADDRESS

This screen shows the IP address for Wi-Fi communications.

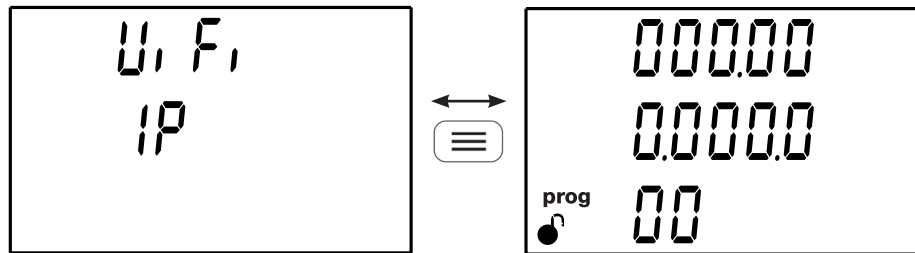

Press the key  to display the value.

To access the following communications screen press the key .

Note: *Wi-Fi communications work only in DHCP mode.*

5.5.7. WI-FI COMMUNICATIONS: MAC ADDRESS

This screen shows the MAC address for Wi-Fi communications.

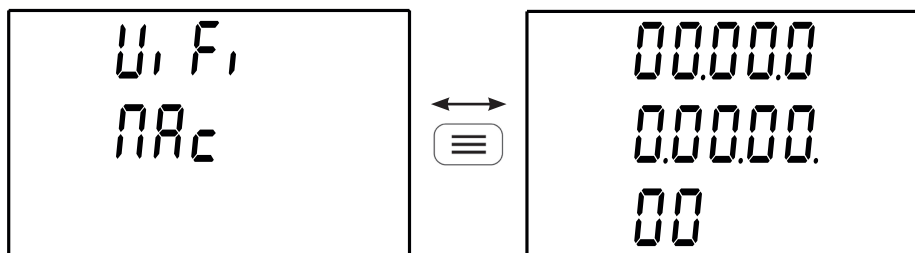

Press the key  to display the value.

To access the following communications screen press the key .

5.5.8. WI-FI COMMUNICATIONS: SIGNAL LEVEL

This screen shows the strength of the Wi-Fi signal.

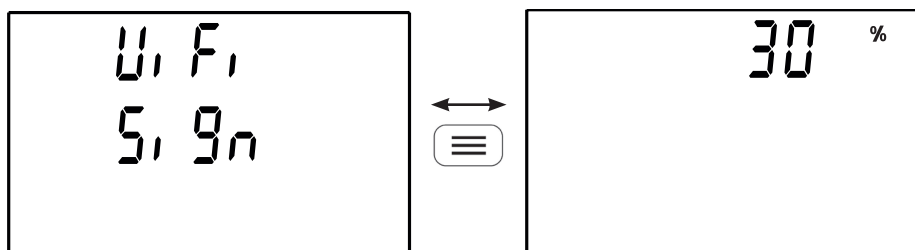

Press the key  to display the value.

To access the following communications screen press the key .

Note: *If Wi-Fi communication is disabled, the text OFF appears on the display.*

Note: *If the signal level is <25%, it is recommended to use Ethernet communications to avoid any incidence in the data recording.*

5.5.9. Bluetooth® COMMUNICATIONS: NAME

This screen shows the device name for Bluetooth® communications.

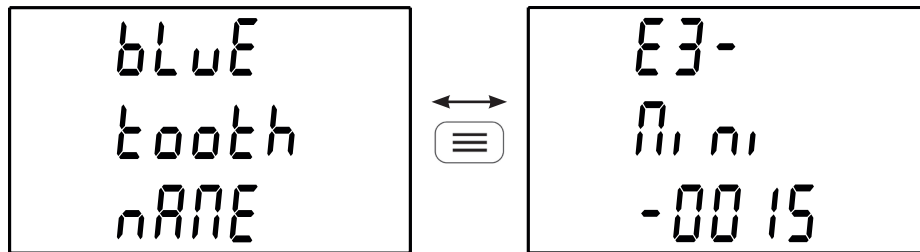



Press the key  to display the value.

Press the   keys simultaneously to exit the Ethernet, Wi-Fi and Bluetooth® communications screens.

6.- CONFIGURATION

To enter the configuration menu press the  key for 3 seconds.

If the  icon appears on the configuration screen, the configuration parameters can be edited.
If the  icon appears, the configuration of the unit will be locked with a password ("**6.23.- LOCKING THE PROGRAMMING**"); when the user tries to edit the value using the , key, the screen in **Figure 31** will be displayed, in which the user must enter the password to unlock.

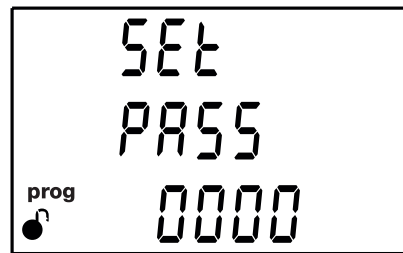





Figure 31: Password screen.

Press the  key to modify the value of the flashing digit.

When the desired value is shown on the screen, use the  and  keys to move the edit cursor.

To validate the password, press the  key if you are on the last digit or the  key if you are on the first digit.

Default password: 1234.

The configuration parameters can be modified after entering the correct password.

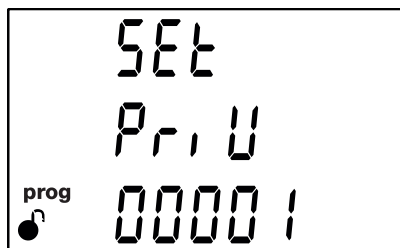

6.1.- PRIMARY VOLTAGE

On this screen the voltage transformer primary is programmed.



Press the  key for 3 seconds to enter the edit mode. The **prog** icon will flash on the left of the screen.

Press the  key to modify the value of the flashing digit.

When the desired value is shown on the screen, use the  and  keys to move the edit cursor.

To validate the value, press the  key for 3 seconds; the **prog** icon will stop flashing.

If the value entered by the user is out of the range of programming values, the programmed value will be deleted and the system will restore it to the last saved value.

✓ Configuration values

Table 21: Configuration values: Primary voltage.

	Primary voltage
Minimum value	1 V
Maximum value	99999 V

Voltage ratio ≤ 1000 .

Voltage ratio x Current ratio ≤ 300000 .

Note: The ratio is the relation between the primary and the secondary.

Press key  to access the next programming step.

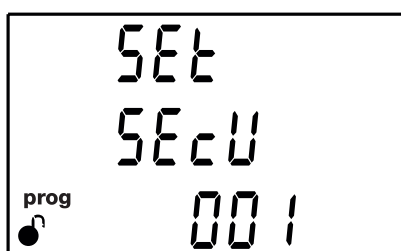

6.2.- SECONDARY VOLTAGE

On this screen the voltage transformer secondary is programmed.



Press the  key for 3 seconds to enter the edit mode. The **prog** icon will flash on the left of the screen.

Press the  key to modify the value of the flashing digit.

When the desired value is shown on the screen, use the  and  keys to move the edit cursor.

To validate the value, press the  key for 3 seconds; the **prog** icon will stop flashing.

If the value entered by the user is out of the range of programming values, the programmed value will be deleted and the system will restore it to the last saved value.

✓ Configuration values

Table 22: Configuration values: Secondary voltage.

	Secondary voltage
Minimum value	1 V
Maximum value	999 V

Voltage ratio ≤ 1000 .

Voltage ratio x Current ratio ≤ 300000 .

Press key  to access the next programming step.

6.3.- PRIMARY CURRENT

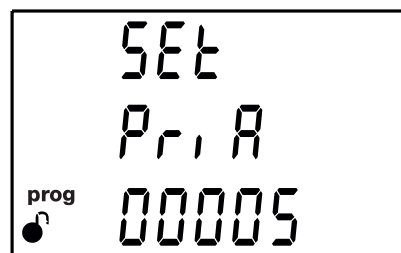

Note: Display visible on models: *CVM-E3-MINI-ITF*, *CVM-E3-MINI-ITF-WiEth*, *CVM-E3-MINI-MC* and *CVM-E3-MINI-MC-WiEth*.

The current transformer primary is programmed on this screen.



Press the  key for 3 seconds to enter the edit mode. The **prog** icon will flash on the left of the screen.

Press the  key to modify the value of the flashing digit.

When the desired value is shown on the screen, use the  and  keys to move the edit cursor.

To validate the value, press the  key for 3 seconds; the **prog** icon will stop flashing.

If the value entered by the user is out of the range of programming values, the programmed value will be deleted and the system will restore it to the last saved value.

✓ Configuration values

Table 23: Configuration values: Primary current.

	Primary current
Minimum value	1 A
Maximum value	10000 A

Voltage ratio x Current ratio \leq 300000.

Note: The ratio is the relation between the primary and the secondary.

Press key  to access the next programming step.

6.4.- SECONDARY CURRENT (MODEL CVM-E3-MINI-ITF)

Note: Display visible on models: CVM-E3-MINI-ITF and CVM-E3-MINI-ITF-WiEth.

On this screen the current transformer secondary is selected.

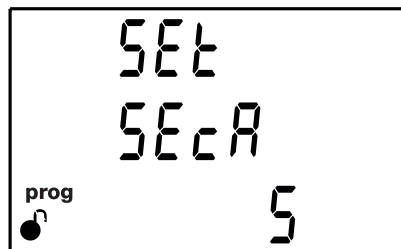

Press the  key for 3 seconds to enter the edit mode. The **prog** icon will flash on the left of the screen.

Use the  key to browse the available options.

✓ Configuration values

Table 24: Configuration values: Secondary current.

	Secondary current	
Possible values	1 A	5 A

Voltage ratio x Current ratio \leq 300000.

To validate the value, press the  key for 3 seconds; the **prog** icon will stop flashing.

Press key  to access the next programming step.

6.5.- FLEX SENSOR

Note: Display visible on models: *CVM-E3-MINI-FLEX* and *CVM-E3-MINI-FLEX-WiEth*.

On this screen, you can select the Rogowski flexible sensor, which will be used to measure the current.



Press the  key for 3 seconds to enter the edit mode. The **prog** icon will flash on the left of the screen.

The key  is used to browse the different options.

✓ Configuration values

Table 25: Configuration values: Flex Sensor.

	Flex Sensor	
Possible values	TYPE 1	Rogowski sensor 100uV/A.
	TYPE 2	Rogowski sensor 76uV/A.

To validate the value, press the  key for 3 seconds; the **prog** icon will stop flashing.

Press key  to access the next programming step.

6.6.- NUMBER OF QUADRANTS

The quadrant number on which the device takes the measurement is selected on this screen.

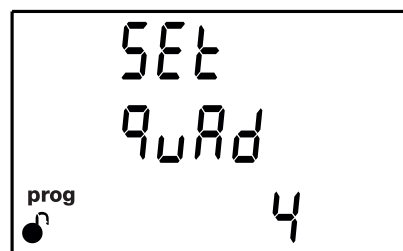

Press the  key for 3 seconds to enter the edit mode. The **prog** icon will flash on the left of the screen.

Use the  key to browse the available options.

✓ Configuration values

Table 26: Configuration values: Number of quadrants.

	Number of quadrants	
Possible values	2	4

To validate the value, press the  key for 3 seconds; the **prog** icon will stop flashing.

Press key  to access the next programming step.

6.7.- MEASUREMENT CONVENTION

You can select the measurement convention of the device from this screen.

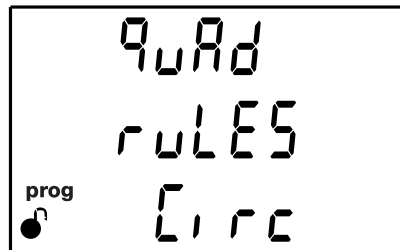

Press the  key for 3 seconds to enter the edit mode. The **prog** icon will flash on the left of the screen.

The key  is used to browse the different options.

✓ Configuration values

Table 27: Configuration values: Measurement convention.

	Measurement convention	
Possible values	Circ	Circutor measurement convention.
	IEC	IEC measurement convention
	IEEE	IEEE measurement convention

To validate the value, press the  key for 3 seconds; the **prog** icon will stop flashing.

Press key  to access the next programming step.

6.8.- MEASUREMENT SYSTEM

The measurement system is selected on this screen.

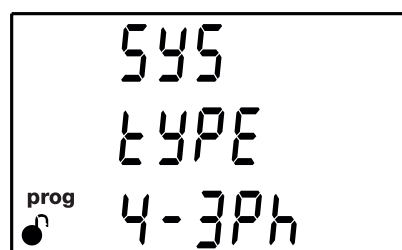

Press the  key for 3 seconds to enter the edit mode. The **prog** icon will flash on the left of the screen.

The  key is used to browse the different options.

✓ Configuration values

Table 28: Configuration values: Measurement system.

	Measurement system	
Possible values	4-3Ph	Three-phase network measurement with a 4-wire connection.
	3-3Ph	Three-phase network measurement with a 3-wire connection
	3-ARON	Three-phase network measurement with a 3-wire connection and transformers with an ARON connection. ⁽⁴⁾
	3-2Ph	Two-phase network measurement with a 3-wire connection.
	2-2Ph	Single-phase network measurement, phase to phase, with a 2-wire connection.
	2-1Ph	Single-phase network measurement, phase to neutral, with a 2-wire connection.

⁽⁴⁾ Option not available for the models: CVM-E3-MINI-FLEX and CVM-E3-MINI-FLEX-WiEth.

To validate the value, press the  key for 3 seconds; the **prog** icon will stop flashing.

Press key  to access the next programming step.

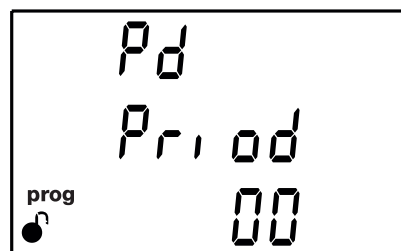

6.9.- MAXIMUM DEMAND INTEGRATION PERIOD

The maximum demand integration period is programmed in minutes on this screen.



Press the  key for 3 seconds to enter the edit mode. The **prog** icon will flash on the left of the screen.

Press the  key to modify the value of the flashing digit.

When the desired value is shown on the screen, use the  and  keys to move the edit cursor.

To validate the value, press the  key for 3 seconds; the **prog** icon will stop flashing. If the value entered by the user is out of the range of programming values, the programmed value will be deleted and the system will restore it to the last saved value.

✓ Configuration values

Table 29: Configuration values: Integration period.

	Integration period
Minimum value	0 minutes
Maximum value	60 minutes

Note: Programming the value **0** disables the calculation of the maximum demand.

Press key  to access the next programming step.

6.10.- DELETING MAXIMUM DEMAND

On this screen you select whether or not to delete the maximum demand.

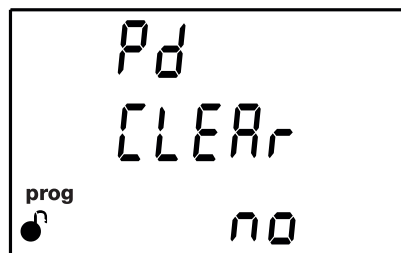

Press the  key for 3 seconds to enter the edit mode. The **prog** icon will flash on the left of the screen.

Use the  key to browse the available options.

✓ Configuration values

Table 30: Configuration values: Deleting Maximum demand.

	Deleting maximum demand	
Possible values	Yes	No

To validate the value, press the  key for 3 seconds; the **prog** icon will stop flashing.

Select **Yes** to force the device to automatically delete all maximum demand data; the **No** option will be displayed again on the screen.

Press key  to access the next programming step.

6.11.- DELETING MAXIMUM AND MINIMUM VALUES

On this screen you select whether or not to delete the maximum and minimum values

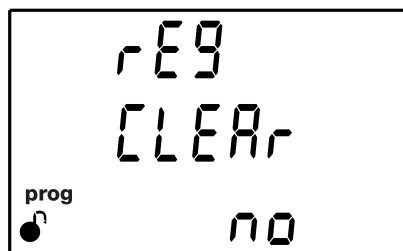

Press the  key for 3 seconds to enter the edit mode. The **prog** icon will flash on the left of the screen.

Use the  key to browse the available options.

✓ Configuration values

Table 31: Configuration values: Deleting Maximum and minimum.

	Deleting maximum and minimum	
Possible values	Yes	No

To validate the value, press the  key for 3 seconds; the **prog** icon will stop flashing.

Select **Yes** to force the device to automatically delete all maximum and minimum values; the **No** option will be displayed again on the screen.

Press key  to access the next programming step.

6.12.- DELETING ENERGY VALUES

On this screen you select whether or not to delete the energy, cost, CO₂ emissions and No. of hours values

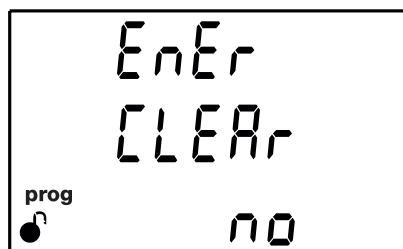

Press the  key for 3 seconds to enter the edit mode. The **prog** icon will flash on the left of the screen.

Use the  key to browse the available options.

✓ Configuration values

Table 32: Configuration values: Deleting Energy.

	Deleting Energy	
Possible values	Yes	No

To validate the value, press the  key for 3 seconds; the **prog** icon will stop flashing.

Select **Yes** to force the device to automatically delete all values; the **No** option will be displayed again on the screen.

Press key  to access the next programming step.

6.13.- ENABLE HARMONICS DISPLAY SCREEN.

This screen is used to select whether harmonics are displayed or not.

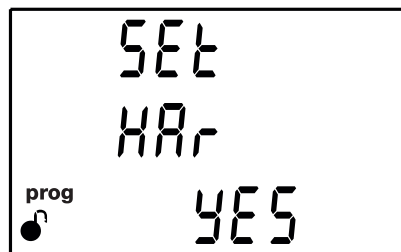

Press the  key for 3 seconds to enter the edit mode. The **prog** icon will flash on the left of the screen.

Use the  key to browse the available options.

✓ Configuration values

Table 33: Configuration values: Harmonics display.

	Harmonics display	
Possible values	Yes	No

To validate the value, press the  key for 3 seconds; the **prog** icon will stop flashing.

Press key  to access the next programming step.

6.14.- kgCO₂ CARBON EMISSION RATIO OF CONSUMED ENERGY

The carbon emissions ratio is the amount of emissions released into the atmosphere to produce a unit of electricity (1 kWh).

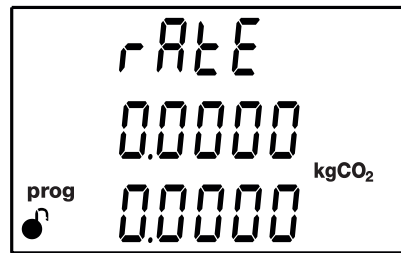

The ratio for the European mix is approximately 0.65 kgCO₂ per kWh.



This screen is used to programme the carbon emissions ratio for consumed energy, using the 2 tariffs configured for the device: **T1** on the top line and **T2** on the bottom line.

Press the  key for 3 seconds to enter the edit mode. The **prog** icon will flash on the left of the screen.

Press the  key to modify the value of the flashing digit.

When the desired value is shown on the screen, use the  and  keys to move the edit cursor.

To validate the value, press the  key for 3 seconds; the **prog** icon will stop flashing.

If the value entered by the user is out of the range of programming values, the programmed value will be deleted and the system will restore it to the last saved value.

✓ Configuration values

Table 34: Configuration values: Carbon emissions ratio (Consumed energy).

	Carbon emissions ratio (Consumed energy)
Minimum value	0
Maximum value	1.9999

Press key  to access the next programming step.

6.15.- kgCO₂ CARBON EMISSION RATIO OF GENERATED ENERGY

The carbon emissions ratio is the amount of emissions released into the atmosphere to produce a unit of electricity (1 kWh).

The ratio for the European mix is approximately 0.65 kgCO₂ per kWh.

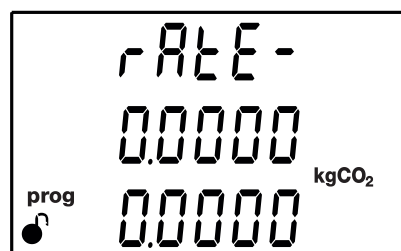

This screen is used to programme the carbon emissions ratio for generated energy, using the 2 tariffs configured for the device: **T1** on the top line and **T2** on the bottom line.

Press the  key for 3 seconds to enter the edit mode. The **prog** icon will flash on the left of the screen.

Press the  key to modify the value of the flashing digit.

When the desired value is shown on the screen, use the  and  keys to move the edit cursor.

To validate the value, press the  key for 3 seconds; the **prog** icon will stop flashing.

If the value entered by the user is out of the range of programming values, the programmed value will be deleted and the system will restore it to the last saved value.

✓ Configuration values

Table 35: Configuration values: Carbon emissions ratio (Generated energy).

	Carbon emissions ratio (Generated energy)
Minimum value	0
Maximum value	1.9999

Press key  to access the next programming step.

6.16.- COST RATIO OF CONSUMED ENERGY

This screen is used to programme the cost per kWh of electricity for consumed energy, using the 2 tariffs configured for the device: **T1** on the top line and **T2** on the bottom line.

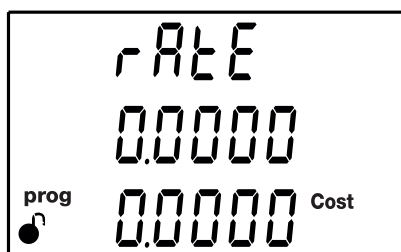

Press the  key for 3 seconds to enter the edit mode. The **prog** icon will flash on the left of the screen.

Press the  key to modify the value of the flashing digit.

When the desired value is shown on the screen, use the  and  keys to move the edit cursor.

To validate the value, press the  key for 3 seconds; the **prog** icon will stop flashing.

If the value entered by the user is out of the range of programming values, the programmed value will be deleted and the system will restore it to the last saved value.

✓ Configuration values

Table 36: Configuration values: Cost ratio (Consumed energy).

	Cost ratio (Consumed energy)
Minimum value	0
Maximum value	1.9999

Press key  to access the next programming step.

6.17.- COST RATIO OF GENERATED ENERGY

This screen is used to programme the cost per kWh of electricity for generated energy, using the 2 tariffs configured for the device: T1 on the top line and T2 on the bottom line.

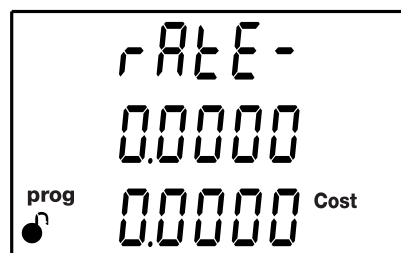

Press the  key for 3 seconds to enter the edit mode. The **prog** icon will flash on the left of the screen.

Press the  key to modify the value of the flashing digit.

When the desired value is shown on the screen, use the  and  keys to move the edit cursor.

To validate the value, press the  key for 3 seconds; the **prog** icon will stop flashing.

If the value entered by the user is out of the range of programming values, the programmed value will be deleted and the system will restore it to the last saved value.

✓ Configuration values

Table 37: Configuration values: Cost ratio (Generated energy).

	Cost ratio (Generated energy)
Minimum value	0
Maximum value	1.9999

Press key  to access the next programming step.

6.18.- PROGRAMMING ALARM : DIGITAL OUTPUT T1

The values corresponding to digital output T1 are programmed in this step.

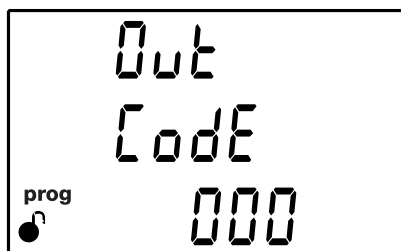

The code of the variable is selected on this screen, according to **Table 38**, **Table 39** and **Table 40**, which will control digital output T1.

Press the  key for 3 seconds to enter the edit mode. The **prog** icon will flash on the left of the screen.

Press the  key to modify the value of the flashing digit.

Set the value to **00** if you do not wish to program a variable.

When the desired value is shown on the screen, use the  and  keys to move the edit cursor.

If an incorrect code has been entered, the value will be deleted and the device will restore the last value saved.

To validate the value, press the  key for 3 seconds; the **prog** icon will stop flashing.

Table 38: Parameter codes used to program the digital output (Table 1).

Parameter	Phase	Code	Phase	Code	Phase	Code	Phase	Code
Phase-Neutral Voltage	L1	01	L2	09	L3	17	-	-
Current	L1	02	L2	10	L3	18	-	-
Active power	L1	03	L2	11	L3	19	III	25
Inductive Reactive Power	L1	04	L2	12	L3	20	III	26
Capacitive Reactive Power	L1	05	L2	13	L3	21	III	27
Apparent power	L1	06	L2	14	L3	22	III	28
Power factor	L1	07	L2	15	L3	23	III	29
Cosine φ	L1	08	L2	16	L3	24	III	30
% THD V	L1	36	L2	37	L3	38	-	-
% THD A	L1	39	L2	40	L3	41	-	-
Phase-Phase Voltage	L1/2	32	L2/3	33	L3/1	34	-	-
Frequency	-	31	-	-	-	-	-	-
Maximum current demand	L1	45	L2	46	L3	47	-	-
Active Power Maximum Demand	-	-	-	-	-	-	III	42
Apparent Power Maximum Demand	-	-	-	-	-	-	III	43

Table 38 (Continuation): Parameter codes used to program the digital output (Table 1).

Parameter	Phase	Code	Phase	Code	Phase	Code	Phase	Code
Inductive Power Maximum Demand	-	-	-	-	-	-	III	132
Capacitive Power Maximum Demand	-	-	-	-	-	-	III	133

In addition, there are some parameters (Table 14) that refer to the three phases at the same time (OR function). If you have selected one of these variables, the alarm will be activated when any of the three phases meets the programmed conditions.

Table 39: Parameter codes used to program the digital output (Table 2).

Types of parameters	Code
Phase-Neutral Voltage	200
Current	201
Active power	202
Inductive Reactive Power	203
Capacitive Reactive Power	204
Power factor	205
Phase-Phase Voltage	206
% THD V	207
% THD A	208
Apparent Power	209

Table 40: Parameter codes used to program the digital output (energy pulses) (Table 3).

Parameter	Tariff	Code	Tariff	Code	Tariff	Code
Consumed active energy	T1	49	T2	70	total	112
Generated active energy	T1	59	T2	80	total	122
Consumed inductive reactive energy	T1	51	T2	72	total	114
Generated inductive reactive energy	T1	61	T2	82	total	124
Consumed capacitive reactive energy	T1	53	T2	74	total	116
Generated capacitive reactive energy	T1	63	T2	84	total	126
Consumed apparent energy	T1	55	T2	76	total	118
Generated apparent energy	T1	65	T2	86	total	128

Press key  to access the next programming step.

If a parameter has been selected from Table 38 or Table 39, the next setup screen will be shown in section "6.18.1. MAXIMUM VALUE".

If a parameter has been selected from Table 40, the next setup screen will be shown in section "6.18.8. KILOWATTS PER PULSE".

6.18.1. MAXIMUM VALUE

This screen is used to programme the maximum value, i.e., the value above which the alarm will be activated.

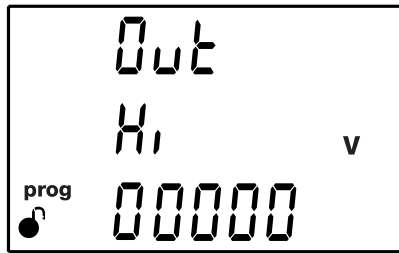

Press the  key for 3 seconds to enter the edit mode. The **prog** icon will flash on the left of the screen.

Press the  key to modify the value of the flashing digit.

Note: The device allows the user to configure negative values. To do so, increase the first digit to a value higher than 9.

When the desired value is shown on the screen, use the  and  keys to move the edit cursor.

Note: Pay *special attention* when programming the Generation Power (displayed with negative values).

Example: If you wish to enter a generation power alarm with limits between 2 kW and 1 kW, program the following as the **maximum value** : - 1 kW and the following as the **minimum value** : - 2 kW.

To validate the value, press the  key for 3 seconds; the **prog** icon will stop flashing.

Press key  to access the next programming step.

6.18.2. MINIMUM VALUE

This screen is used to programme the minimum value, i.e., the value under which the alarm will be activated.

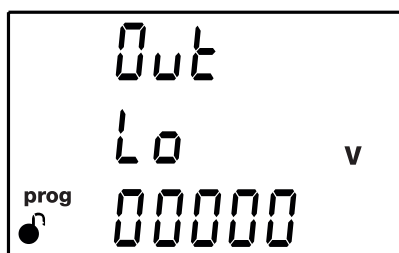

Press the  key for 3 seconds to enter the edit mode. The **prog** icon will flash on the left of the screen.

Press the  key to modify the value of the flashing digit.

Note: The device allows the user to configure negative values. To do so, increase the first digit to a value higher than 9.

When the desired value is shown on the screen, use the  and  keys to move the edit cursor.

Note: Pay *special attention* when programming the Generation Power (displayed with negative values).
Example: If you wish to enter a generation power alarm with limits between 2 kW and 1 kW, program the following as the **maximum value** : - 1 kW and the following as the **minimum value** : - 2 kW.

To validate the value, press the  key for 3 seconds; the **prog** icon will stop flashing.

Press key  to access the next programming step.

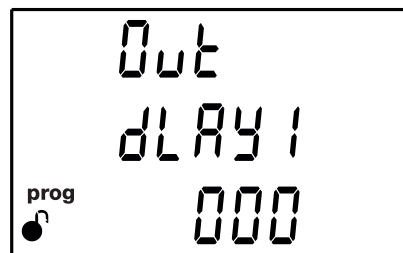

6.18.3. CONNECTION TIME DELAY

The alarm connection delay is programmed on this screen in seconds.



Press the  key for 3 seconds to enter the edit mode. The **prog** icon will flash on the left of the screen.

Press the  key to modify the value of the flashing digit.

When the desired value is shown on the screen, use the  and  keys to move the edit cursor.

To validate the value, press the  key for 3 seconds; the **prog** icon will stop flashing.

✓ Configuration values

Table 41: Configuration values: Connection time delay

	Connection time delay
Minimum value	0
Maximum value	999

Press key  to access the next programming step.

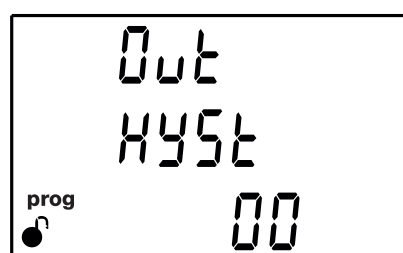

6.18.4. HYSTERESIS VALUE

The hysteresis value, i.e., difference between the alarm connection and disconnection value, in %, is programmed on this screen.



Press the  key for 3 seconds to enter the edit mode. The **prog** icon will flash on the left of the screen.

Press the  key to modify the value of the flashing digit.

When the desired value is shown on the screen, use the  and  keys to move the edit cursor. To validate the value, press the  key for 3 seconds; the **prog** icon will stop flashing.

✓ Configuration values

Table 42: Configuration values: Hysteresis.

	Hysteresis
Minimum value	0 %
Maximum value	99 %

Press key  to access the next programming step.

6.18.5. LATCH

The interlocking is selected on this screen, i.e., if the alarm is interlocked after it has been tripped, even when the condition that triggered it has disappeared.

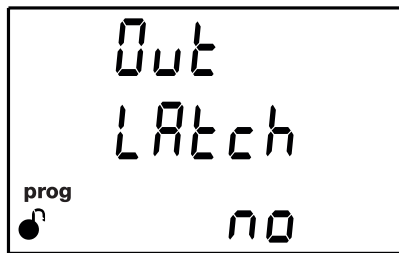

Press the  key for 3 seconds to enter the edit mode. The **prog** icon will flash on the left of the screen.

Use the  key to browse the available options.

✓ Configuration values

Table 43: Configuration values: Latch.

	Latch	
Possible values	Yes	No

To validate the value, press the  key for 3 seconds; the **prog** icon will stop flashing.

Press key  to access the next programming step.

Note: If the device is reset, the status of alarms is deleted and all alarms will return to the programmed standby status, provided that the condition that triggered them has been resolved.

6.18.6. LATCH TIME

Note: Screen visible if the latch has been enabled, see "6.18.5. LATCH".

This screen is used to program the latch time, meaning the time in seconds when the alarm will be latched. After this time, if the alarm condition has cleared, the disconnection delay is activated

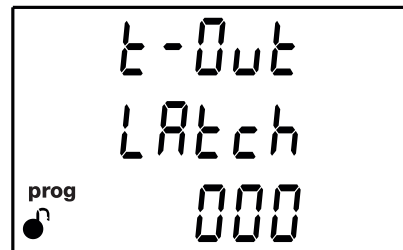

Press the  key for 3 seconds to enter the edit mode. The **prog** icon will flash on the left of the screen.

Use the  key to browse the available options.

✓ Configuration values

Table 44: Configuration values: Latch time.

	Latch time
Minimum value	0 s.
Maximum value	600 s.

Note: If a 0 is programmed, the alarm remains latched and can only be unlatched manually.

To validate the value, press the  key for 3 seconds; the **prog** icon will stop flashing.

Press key  to access the next programming step.

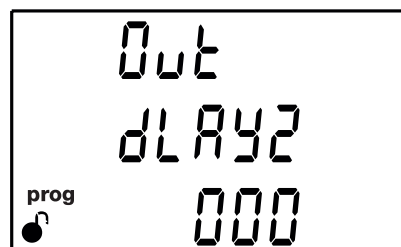

6.18.7. DISCONNECTION TIME DELAY

The alarm disconnection delay is programmed on this screen in seconds.



Press the  key for 3 seconds to enter the edit mode. The **prog** icon will flash on the left of the screen.

Press the  key to modify the value of the flashing digit.

When the desired value is shown on the screen, use the  and  keys to move the edit cursor.

To validate the value, press the  key for 3 seconds; the **prog** icon will stop flashing.

✓ Configuration values

Table 45: Configuration values: Disconnection time delay.

	Disconnection time delay
Minimum value	0 s.
Maximum value	999 s.

Press key  to access the next programming step.

6.18.8. CONTACT STATUS

The status of relay contacts is selected on this screen.



Press the  key for 3 seconds to enter the edit mode. The **prog** icon will flash on the left of the screen.

Press key  to browse options.

✓ Configuration values

Table 46: Configuration values: Contact status

	Contact status	
Possible values	n0	Normally open contact.
	nC	Normally closed contact.

To validate the value, press the  key for 3 seconds; the **prog** icon will stop flashing.

Press key  to access the next programming step.

6.18.9. KILOWATTS PER PULSE

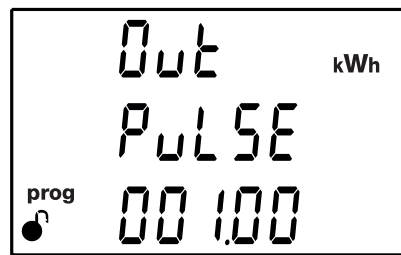

Note: This screen is displayed if the alarm parameter has been selected from an energy value, see Table 40.

This screen is used to programme the kilowatts per pulse.



Press the  key for 3 seconds to enter the edit mode. The **prog** icon will flash on the left of the screen.

Press the  key to modify the value of the flashing digit.

When the desired value is shown on the screen, use the  and  keys to move the edit cursor.

✓ Configuration values

Table 47: Configuration values: Kilowatts per pulse.

	Kilowatts per pulse
Minimum value	000.01 kWh.
Maximum value	999.99 kWh

To validate the value, press the  key for 3 seconds; the **prog** icon will stop flashing.

If the value entered by the user is out of the range of programming values, the programmed value will be deleted and the system will restore it to the last saved value.

Press key  to access the next programming step.

6.18.10. PULSE WIDTH

Note: This screen is displayed if the alarm parameter has been selected from an energy value, see Table 40.

The width of the pulse is selected on this screen in ms.



Press the  key for 3 seconds to enter the edit mode. The **prog** icon will flash on the left of the screen.

Press the  key to modify the value of the flashing digit.

When the desired value is shown on the screen, use the  and  keys to move the edit cursor.

✓ Configuration values

Table 48: Configuration values: Pulse width.

	Pulse width
Minimum value	30 ms.
Maximum value	500 ms.

To validate the value, press the  key for 3 seconds; the **prog** icon will stop flashing.

If the value entered by the user is out of the range of programming values, the programmed value will be deleted and the system will restore it to the last saved value.

Press key  to access the next programming step.

6.19.- OPERATING MODE OF DIGITAL INPUT (Models CVM-E3-MINI-xxx)

The function of digital input 1 is selected on this screen.

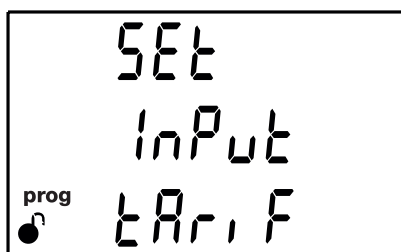

Press the  key for 3 seconds to enter the edit mode. The **prog** icon will flash on the left of the screen.

Press key  to browse the two options.

✓ Configuration values

Table 49: Configuration values: digital input.

	Digital input	
Possible values	LOGIC	Logic input
	TARIF	Tariff selection.

Note: The Digital Input can be set up as a pulse counter via RS-485 communications, see "7.3.9.12 Digital input (Models CVM-E3-MINI-xxx)".

To validate the value, press the  key for 3 seconds; the **prog** icon will stop flashing.

Press key  to access the next programming step.

6.20.- TARIFF SELECTION (Models CVM-E3-MINI-xxx-WiEth)

You can select the operating tariff on this screen.

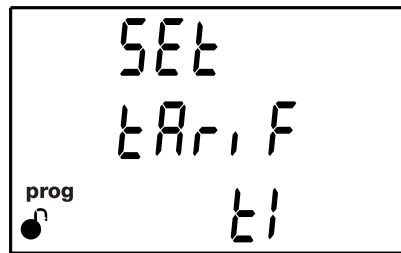



Press the  key for 3 seconds to enter the edit mode. The **prog** icon will flash on the left of the screen.

Press key  to browse the two options.

✓ Configuration values

Table 50: Configuration values: Tariff.

	Tariff	
Possible values	t1	Tariff 1
	t2	Tariff 2

To validate the value, press the  key for 3 seconds; the **prog** icon will stop flashing. Press key  to access the next programming step.

6.21.- BACKLIGHT, TURNING ON THE BACKLIT DISPLAY

This screen is used to programme the maximum brightness time of the display since the device was last used with the keypad. After this time, the display will reduce the brightness level.



Press the  key for 3 seconds to enter the edit mode. The **prog** icon will flash on the left of the screen.

Press the  key to modify the value of the flashing digit.

When the desired value is shown on the screen, use the  and  keys to move the edit cursor.

✓ Configuration values

Table 51: Configuration values: Backlight

	Backlight
Minimum value	1 second.
Maximum value	999 seconds.

To validate the value, press the  key for 3 seconds; the **prog** icon will stop flashing.

If the value entered by the user is out of the range of programming values, the programmed value will be deleted and the system will restore it to the last saved value.

Press key  to access the next programming step.

6.22.- RS-485 COMMUNICATIONS (Models CVM-E3-MINI-xxx)

The RS-485 communications protocol is selected on this screen.

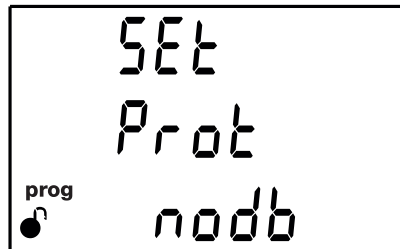

Press the  key for 3 seconds to enter the edit mode. The **prog** icon will flash on the left of the screen.

Press key  to browse the two options.

✓ Configuration values

Table 52: Configuration values: RS-485 communications.

	RS-485 communications	
Possible values	nodb	Modbus
	bAcn	BACnet.

To validate the value, press the  key for 3 seconds; the **prog** icon will stop flashing.

Press key  to access the next programming step.

Note: The device will restart after exiting the setup menu if the RS-485 communications parameters have been modified.

If the Modbus protocol has been selected, the next setup screen will be shown in section "6.22.1. MODBUS PROTOCOL: BAUD RATE".

If the BACnet protocol has been selected, the next setup screen will be shown in section “6.22.6.- BACnet PROTOCOL: BAUD RATE”.

6.22.1.- MODBUS PROTOCOL: BAUD RATE

The baud rate of modbus communications is programmed on this screen.

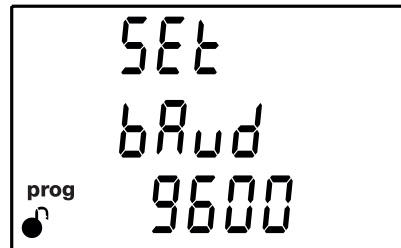

Press the  key for 3 seconds to enter the edit mode. The **prog** icon will flash on the left of the screen.

Press key  to browse the options.

✓ Configuration values

Table 53: Configuration values: Modbus protocol: baud rate

	Baud rate				
Possible values	9600	19200	38400 ⁽⁵⁾	57600 ⁽⁵⁾	115200 ⁽⁵⁾

⁽⁵⁾ Available on devices with software version v2.xx.

To validate the value, press the  key for 3 seconds; the **prog** icon will stop flashing.

Press key  to access the next programming step.

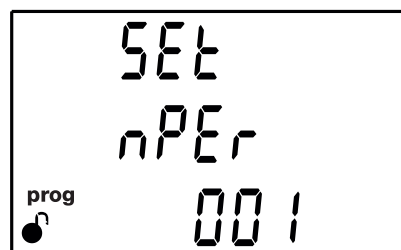

6.22.2.- MODBUS PROTOCOL: PERIPHERAL NUMBER

The peripheral number is programmed on this screen.



Press the  key for 3 seconds to enter the edit mode. The **prog** icon will flash on the left of the screen.

Press the  key to modify the value of the flashing digit.

When the desired value is shown on the screen, use the  and  keys to move the edit cursor.

✓ Configuration values

Table 54: Configuration values: Modbus protocol: Peripheral number

	Peripheral number
Minimum value	1
Maximum value	255

To validate the value, press the  key for 3 seconds; the **prog** icon will stop flashing.

If the value entered by the user is out of the range of programming values, the programmed value will be deleted and the system will restore it to the last saved value.

Press key  to access the next programming step.

6.22.3.- MODBUS PROTOCOL: PARITY

The type of parity of Modbus communications is selected on this screen.

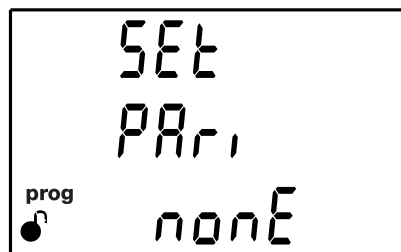

Press the  key for 3 seconds to enter the edit mode. The **prog** icon will flash on the left of the screen.

Press key  to browse the options.

✓ Configuration values

Table 55: Configuration values: Modbus protocol: Parity

	Parity	
Possible values	<i>none</i>	no parity
	<i>Even</i>	even parity
	<i>odd</i>	odd parity

To validate the value, press the  key for 3 seconds; the **prog** icon will stop flashing.

Press key  to access the next programming step.

6.22.4.- MODBUS PROTOCOL: DATA BITS

The number of data bits of Modbus communications are programmed on this screen.

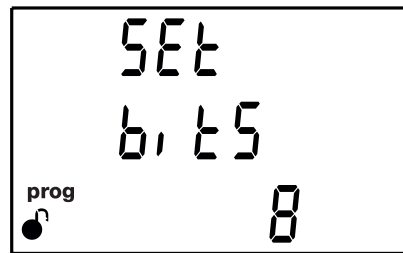

Press the  key for 3 seconds to enter the edit mode. The **prog** icon will flash on the left of the screen.

Press key  to browse the options.

✓ Configuration values

Table 56: Configuration values: Modbus protocol: data bits.

	Data bits	
Possible values	7	8

To validate the value, press the  key for 3 seconds; the **prog** icon will stop flashing.

Press key  to access the next programming step.

6.22.5.- MODBUS PROTOCOL : STOP BITS

The number of Stop bits of Modbus communications are programmed on this screen.

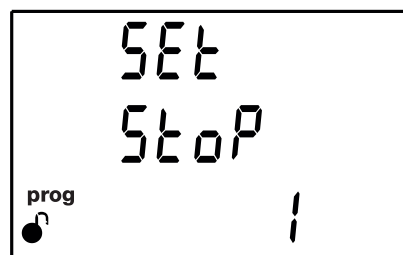

Press the  key for 3 seconds to enter the edit mode. The **prog** icon will flash on the left of the screen.

Press key  to browse the options.

✓ Configuration values

Table 57: Configuration values: Modbus protocol: stop bits.

	Stop bits	
Possible values	1	2

To validate the value, press the  key for 3 seconds; the **prog** icon will stop flashing.

Press key  to access the next programming step.

6.22.6.- BACnet PROTOCOL : BAUD RATE

The baud rate of BACnet communications is programmed on this screen.

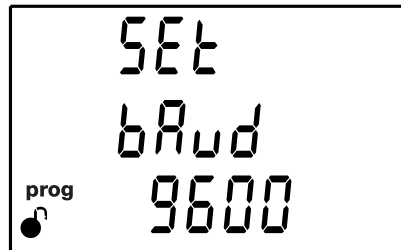

Press the  key for 3 seconds to enter the edit mode. The **prog** icon will flash on the left of the screen.

Press key  to browse the options.

✓ Configuration values

Table 58: Configuration values: BACnet protocol: baud rate

	Baud rate				
Possible values	9600	19200	38400 ⁽⁶⁾	57600 ⁽⁶⁾	115200 ⁽⁶⁾

⁽⁶⁾ Available on devices with software version **v2.xx**.

To validate the value, press the  key for 3 seconds; the **prog** icon will stop flashing.

Press key  to access the next programming step.

6.22.7.- BACnet PROTOCOL : ID

The device ID is programmed on this screen.

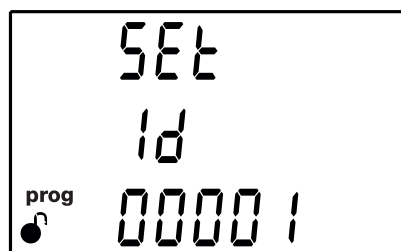

Press the  key for 3 seconds to enter the edit mode. The **prog** icon will flash on the left of the screen.

Press the  key to modify the value of the flashing digit.

When the desired value is shown on the screen, use the  and  keys to move the edit cursor.

✓ Configuration values

Table 59: Configuration values: BACnet protocol: ID.

	ID
Minimum value	0
Maximum value	99999

To validate the value, press the  key for 3 seconds; the **prog** icon will stop flashing.

If the value entered by the user is out of the range of programming values, the programmed value will be deleted and the system will restore it to the last saved value.

Press key  to access the next programming step.

6.22.8.- BACnet PROTOCOL : MAC ADDRESS

The MAC address is programmed on this screen.

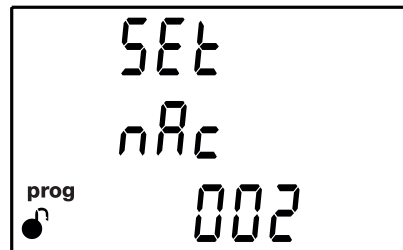

Press the  key for 3 seconds to enter the edit mode. The **prog** icon will flash on the left of the screen.

Press the  key to modify the value of the flashing digit.

When the desired value is shown on the screen, use the  and  keys to move the edit cursor.

✓ Configuration values

Table 60: Configuration values: BACnet protocol: MAC address.

	MAC address
Minimum value	0
Maximum value	127

To validate the value, press the  key for 3 seconds; the **prog** icon will stop flashing.

If the value entered by the user is out of the range of programming values, the programmed value will be deleted and the system will restore it to the last saved value.

Press key  to access the next programming step.

6.23.- LOCKING THE PROGRAMMING

This screen is for protecting the data configured in the programming menu.

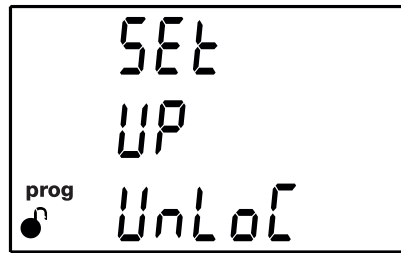

Press the  key for 3 seconds to enter the edit mode. The screen shown in Figure 32 will be displayed, in which the user must enter the locking password.

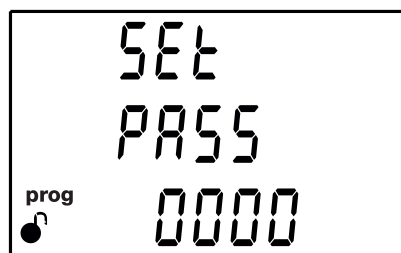

Figure 32: Password screen.

Press the  key to modify the value of the flashing digit.

When the desired value is shown on the screen, use the  and  keys to move the edit cursor.

To validate the value, press the  key for 3 seconds; the **prog** icon will stop flashing.



Password value: 1234

The programming lock parameters can be modified after entering the correct password.

Use the  key to browse the available options:

✓ Configuration values

Table 61: Configuration values: Locking the programming.

Locking the programming		
Possible values	UnLoC	When you enter the programming menu you can view and modify the programming. Icon  on the display indicates the permanently locked status.
	LoC	When you enter the programming you can view the programming but not modify it. Icon  indicates the locking status. Enter the password to modify the programming values.

To validate the data, press  for 3 seconds and the **prog** icon will disappear from the display.



Press the  key to enter the password for locking and unlocking the programming:

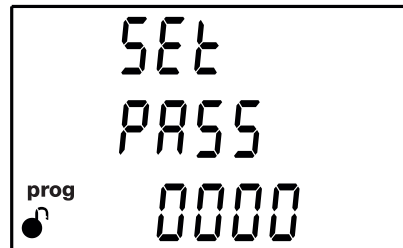

6.23.1.- PASSWORD

On this screen you enter the password for locking and unlocking the programming.



Press the  key to modify the value of the flashing digit.

When the desired value is shown on the screen, use the  and  keys to move the edit cursor.

To validate the password, press the  key if you are on the last digit or the  key if you are on the first digit.

Password value : 1234

This value may only be modified through communications. See *"7.3.9.16. Password configuration."*

7.- CVM-E3-MINI-xxx : RS-485 COMMUNICATIONS

The **CVM-E3-MINI-xxx** devices have one RS-485 communications port.

The device has as standard two communications protocols: **MODBUS RTU** ® and **BACnet**.

The protocol and configuration parameters are selected in the setup menu. ("6.22.- *RS-485 COMMUNICATIONS (Models CVM-E3-MINI-xxx)*").

7.1.- CONNECTIONS

The RS -485 cable must be wired with twisted pair cable with mesh shield (minimum 3 wires), with a maximum distance between the **CVM-E3-MINI** and the master device of 1200 metres.

A maximum of 32 **CVM-E3-MINI** devices can be connected to this bus.

Use an intelligent RS-232 to RS-485 network protocol converter to establish the communications with the master device.

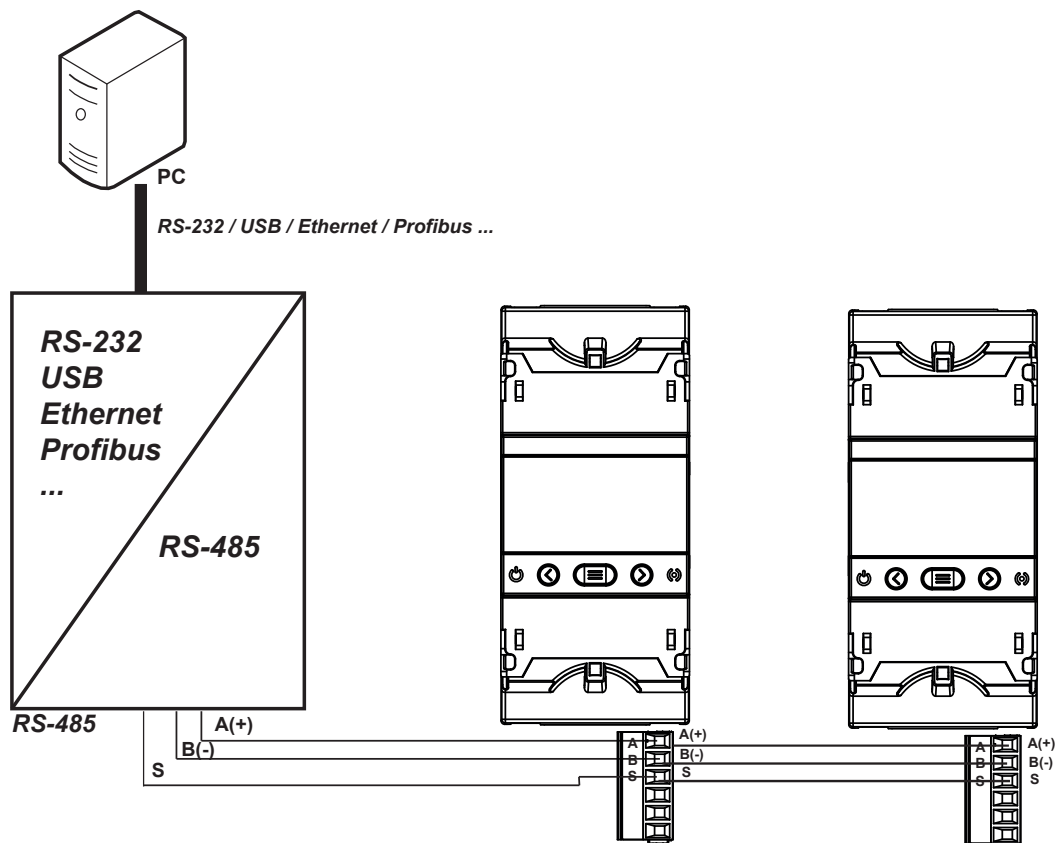

Figure 33: RS-485 Connection diagram.

7.2.- MODBUS PROTOCOL

In the Modbus protocol, the **CVM-E3-MINI** device uses the RTU (Remote Terminal Unit) mode. The Modbus functions implemented in the device are as follows:

Function 0x03 and 0x04. Reading integer registers.

Function 0x05. Writing a relay.

Function 0x10. Writing multiple registers.

7.2.1.- READING EXAMPLE : Funtion 0x04.

Question: Instantaneous value of the phase voltage of L1

Address	Function	Initial register	No. of registers	CRC
0A	04	0000	0002	70B0

Address: 0A, Peripheral number: 10 in decimals.

Function: 04, Read function.

Initial Register: 0000, register on which the reading will start.

No. of registers: 0002, number of registers read.

CRC: 70B0, CRC Character.

Response:

Address	Function	No. of Bytes	Register No. 1	Register No. 2	CRC
0A	04	04	0000	084D	8621

Address: 0A, Responding peripheral number: 10 in decimals.

Function: 04, Read function.

No. of bytes: 04, No. of bytes received.

Register: 0000084D, value of the phase voltage of L1: VL1 x 10 : 212.5V

CRC: 8621, CRC Character.

Note: Every Modbus frame has a maximum limit of 20 variables (40 logs).

7.2.2.- WRITING EXAMPLE : Funtion 0x05.

Question: Deleting maximum and minimum values.

Address	Function	Initial Register	Value	CRC
0A	05	0834	FF00	CEEF

Address: 0A, Peripheral number: 10 in decimal.

Function: 05, Read function.

Initial register: 0834, register of the parameter for deleting maximum and minimum values.

Value: FF00, we indicate that we want to delete the maximum and minimum values.

CRC: CEEF, CRC character.

Response:

Address	Function	Initial register	Value	CRC
0A	05	0834	FF00	CEEF

7.3.- MODBUS COMMANDS

Two different memory maps have been implemented for the Measurement, Energy and Voltage and Current harmonics variables. However, they have the same functions:

- ✓ **Map 1**, uses the addresses of the **CVM-MINI** device, entering the addresses of the new parameters measured by this new device.
- ✓ **Map 2**, uses the addresses of the **CVM-C10** device (adding 0x1000 to all addresses). Except for 3 parameters, the **CVM-C10** and the **CVM-E3-MINI** use the same parameters.

Map 2 should be used if a Modbus map is going to be implemented from scratch. However, if the map is already being used in another device, use **Map 1** for **CVM-MINI** and **Map 2** for **CVM-C10**.

All the addresses of Modbus memory are in Hexadecimal.

Note: On devices with software version $\geq v2.xx$ it is necessary to use a time out ≥ 200 ms and a cadence between frames ≥ 100 ms.

7.3.1. MEASUREMENT VARIABLES

For these variables is implemented the **Function 0x03** and **0x04**.

Table 62: Modbus memory Map 1: Measurement variables

Map 1					
Parameter	Symbol	Instantaneous	Maximum	Minimum	Units
L1 Phase voltage	V 1	00-01	60-61	C0-C1	V x 10
L1 Current	A 1	02-03	62-63	C2-C3	mA
L1 Active Power	kW 1	04-05	64-65	C4-C5	W
L1 Reactive Power	kvar 1	06-07	66-67	C6-C7	var
L1 Inductive Power	kvarL 1	12C-12D	13E-13F	150-151	var
L1 Capacitive Power	kvarC 1	12E-12F	140-141	152-153	var
L1 Apparent Power	kVA 1	4A-4B	AA-AB	10A-10B	VA
L1 Power Factor	PF 1	08-09	68-69	C8-C9	x 100
Cos φ L1	Cos φ 1	130-131	142-143	154-155	x 100
L2 Phase voltage	V 2	0A-0B	6A-6B	CA-CB	V x 10
L2 Current	A 2	0C-0D	6C-6D	CC-CD	mA
L2 Active Power	kW 2	0E-0F	6E-6F	CE-CF	W
L2 Reactive Power	kvar 2	10-11	70-71	D0-D1	var
L2 Inductive Power	kvarL 2	132-133	144-145	156-157	var
L2 Capacitive Power	kvarC 2	134-135	146-147	158-159	var
L2 Apparent Power	kVA 2	4C-4D	AC-AD	10C-10D	VA

Table 62 (Continuation): Modbus memory Map 1: Measurement variables

Mapa 1					
Parameter	Symbol	Instantaneous	Maximum	Minimum	Units
L2 Power Factor	PF 2	12-13	72-73	D2-D3	x 100
Cos ϕ L2	Cos ϕ 2	136-137	148-149	15A-15B	x 100
L3 Phase voltage	V 3	14-15	74-75	D4-D5	V x 10
L3 Current	A 3	16-17	76-77	D6-D7	mA
L3 Active Power	kW 3	18-19	78-79	D8-D9	W
L3 Reactive Power	kvar 3	1A-1B	7A-7B	DA-DB	var
L3 Inductive Power	kvarL 3	138-139	14A-14B	15C-15D	var
L3 Capacitive Power	kvarC 3	13A-13B	14C-14D	15E-15F	var
L3 Apparent Power	kVA 3	4E-4F	AE-AF	10E-10F	VA
L3 Power Factor	PF 3	1C-1D	7C-7D	DC-DD	x 100
Cos ϕ L3	Cos ϕ 3	13C-13D	14E-14F	160-161	x 100
Three-phase Active Power	kW III	1E-1F	7E-7F	DE-DF	W
Three-phase Inductive power	kvarL III	20-21	80-81	E0-E1	var
Three-phase Capacitive Power	kvarC III	22-23	82-83	E2-E3	var
Three-phase Apparent power	kVA III	42-43	A2-A3	102-103	VA
Three-phase Power Factor	PF III	26-27	86-87	E6-E7	x100
Three-phase Cos ϕ	Cos ϕ III	24-25	84-85	E4-E5	x100
L1 Frequency	Hz	28-29	88-89	E8-E9	Hz x10
L1-L2 Voltage	V12	2A-2B	8A-8B	EA-EB	V x 10
L2-L3 Voltage	V23	2C-2D	8C-8D	EC-ED	V x 10
L3-L1 Voltage	V31	2E-2F	8E-8F	EE-EF	V x 10
% L1 voltage THD	%THDV1	30-31	90-91	F0-F1	% x 10
% L2 voltage THD	%THDV2	32-33	92-93	F2-F3	% x 10
% L3 voltage THD	%THDV3	34-35	94-95	F4-F5	% x 10
% L1 current THD	%THDI1	36-37	96-97	F6-F7	% x 10
% L2 current THD	%THDI2	38-39	98-99	F8-F9	% x 10
% L3 current THD	%THDI3	3A-3B	9A-9B	FA-FB	% x 10
Maximum demand kW III	Md(Pd)	162-163	16A-16B	-	W
Maximum demand kVA III	Md(Pd)	164-165	16C-16D	-	VA
Maximum demand kvarL III	Md(Pd)	166-167	16E-16F	-	var
Maximum demand kvarC III	Md(Pd)	168-169	170-171	-	var
Maximum demand I L1	Md(Pd)	44-45	A4-A5	-	mA
Maximum demand I L2	Md(Pd)	52-53	B2-B3	-	mA
Maximum demand I L3	Md(Pd)	54-55	B4-B5	-	mA
Three-phase current (average)	A AVG	46-47	A6-A7	106-417	mA
Neutral Current	A	48-49	A8-A9	108-109	mA
Temperature	Temp	50-51	B0-B1	110-111	$^{\circ}\text{C} \times 10$

Table 63: Modbus memory Map 2: Measurement variables

Map 2					
Parameter	Symbol	Instantaneous	Maximum	Minimum	Units
L1 Phase voltage	V 1	1000-1001	1106-1107	1164-1165	V x 10
L1 Current	A 1	1002-1003	1108-1109	1166-1167	mA

Tabla 63 (Continuation): Modbus memory Map 2: Measurement variables

Map 2					
Parameter	Symbol	Instantaneous	Maximum	Minimum	Units
L1 Active Power	kW 1	1004-1005	110A-110B	1168-1169	W
L1 Inductive Power	kvarL 1	1006-1007	110C-110D	116A-116B	var
L1 Capacitive Power	kvarC 1	1008-1009	110E-110F	116C-116D	var
L1 Apparent Power	kVA 1	100A-100B	1110-1111	116E-116F	VA
L1 Power Factor	PF 1	100C-100D	1112-1113	1170-1171	x 100
Cos ϕ L1	Cos ϕ 1	100E-100F	1114-1115	1172-1173	x 100
L2 Phase voltage	V 2	1010-1011	1116-1117	1174-1175	V x 10
L2 Current	A 2	1012-1013	1118-1119	1176-1177	mA
L2 Active Power	kW 2	1014-1015	111A-111B	1178-1179	W
L2 Inductive Power	kvarL 2	1016-1017	111C-111D	117A-117B	var
L2 Capacitive Power	kvarC 2	1018-1019	111E-111F	117C-117D	var
L2 Apparent Power	kVA 2	101A-101B	1120-1121	117E-117F	VA
L2 Power Factor	PF 2	101C-101D	1122-1123	1180-1181	x 100
Cos ϕ L2	Cos ϕ 2	101E-101F	1124-1125	1182-1183	x 100
L3 Phase voltage	V 3	1020-1021	1126-1127	1184-1185	V x 10
L3 Current	A 3	1022-1023	1128-1129	1186-1187	mA
L3 Active Power	kW 3	1024-1025	112A-112B	1188-1189	W
L3 Inductive Power	kvarL 3	1026-1027	112C-112D	118A-118B	var
L3 Capacitive Power	kvarC 3	1028-1029	112E-112F	118C-118D	var
L3 Apparent Power	kVA 3	102A-102B	1130-1131	118E-118F	VA
L3 Power Factor	PF 3	102C-102D	1132-1133	1190-1191	x 100
Cos ϕ L3	Cos ϕ 3	102E-102F	1134-1135	1192-1193	x 100
Three-phase Active Power	kW III	1030-1031	1136-1137	1194-1195	W
Three-phase Inductive power	kvarL III	1032-1033	1138-1139	1196-1197	var
Three-phase Capacitive Power	kvarC III	1034-1035	113A-113B	1198-1199	var
Three-phase Apparent power	kVA III	1036-1037	113C-113D	119A-119B	VA
Three-phase Power Factor	PF III	1038-1039	113E-113F	119C-119D	x100
Three-phase Cos ϕ	Cos ϕ III	103A-103B	1140-1141	119E-119F	x100
L1 Frequency	Hz	103C-103D	1142-1143	11A0-11A1	Hz x100
L1-L2 Voltage	V12	103E-103F	1144-1145	11A2-11A3	V x 10
L2-L3 Voltage	V23	1040-1041	1146-1147	11A4-11A5	V x 10
L3-L1 Voltage	V31	1042-1043	1148-1149	11A6-11A7	V x 10
Neutral Current	A	1044-1045	114A-114B	11A8-11A9	mA
% L1 voltage THD	%THDV1	1046-1047	114C-114D	11AA-11AB	% x 10
% L2 voltage THD	%THDV2	1048-1049	114E-114F	11AC-11AD	% x 10
% L3 voltage THD	%THDV3	104A-104B	1150-1151	11AE-11AF	% x 10
% L1 current THD	%THDI1	104C-104D	1152-1153	11B0-11B1	% x 10
% L2 current THD	%THDI2	104E-104F	1154-1155	11B2-11B3	% x 10
% L3 current THD	%THDI3	1050-1051	1156-1157	11B4-11B5	% x 10
Maximum demand kW III	Md(Pd)	1052-1053	1158-1159	-	W
Maximum demand kVA III	Md(Pd)	1054-1055	115A-115B	-	VA
Maximum demand kvarL III	Md(Pd)	1200-1201	1204-1205	-	var
Maximum demand kvarC III	Md(Pd)	1202-1203	1206-1207	-	var

Tabla 63 (Continuation): Modbus memory Map 2: Measurement variables

Map 2					
Parameter	Symbol	Instantaneous	Maximum	Minimum	Units
Maximum demand I L1	Md(Pd)	1058-1059	115E-115F	-	mA
Maximum demand I L2	Md(Pd)	105A-105B	1160-1161	-	mA
Maximum demand I L3	Md(Pd)	105C-105D	1162-1163	-	mA

7.3.2. ENERGY VARIABLES

For these variables is implemented the **Function 0x03** and **0x04**.

Table 64: Modbus memory Map 1 (Instantaneous energy variables)

Map 1			
Parameter	Symbol	instantaneous	Units
Active energy III	kWh III	3C-3D	Wh
Inductive reactive energy III	kvarhL III	3E-3F	varhL
Capacitive reactive energy III	kvarhC III	40-41	varhC
Apparent energy III	kVAh III	56-57	VAh
Generated active energy III	kWh III	58-59	Wh
Generated inductive reactive energy III	kvarhL III	5A-5B	varhL
Generated capacitive reactive energy III	kvarhC III	5C-5D	varhC
Generated apparent energy III	kVAh III	5E-5F	VAh

Table 65: Modbus memory Map 1: Energy variables

Map 1					
Parameter	Symbol	Tariff 1	Tariff 2	Total	Units
Consumed active energy III (kWh)	kWh III	18C-18D	1B6-1B7	1E0-1E1	kWh
Consumed active energy III (Wh)	kWh III	18E-18F	1B8-1B9	172-173	Wh
Consumed inductive reactive energy III (kvarhL)	kvarhL III	190-191	1BA-1BB	1E2-1E3	kvarh
Consumed inductive reactive energy III (varhL)	kvarhL III	192-193	1BC-1BD	174-175	varh
Consumed capacitive reactive energy III (kvarhC)	kvarhC III	194-195	1BE-1BF	1E4-1E5	kvarh
Consumed capacitive reactive energy III (varhC)	kvarhC III	196-197	1C0-1C1	176-176	varh
Consumed apparent energy III (kVAh)	kVAh III	198-199	1C2-1C3	1E6-1E7	kVAh
Consumed apparent energy III (VAh)	kVAh III	19A-19B	1C4-1C5	178-179	VAh
Consumed CO ₂ emissions	KgCO ₂	1AC-1AD	1D6-1D7	182-183	KgCO ₂
Consumption cost	\$	1AE-1AF	1D8-1D9	184-185	\$
Generated active energy III (kWh)	kWh III	19C-19D	1C6-1C7	1E8-1E9	kWh
Generated active energy III (Wh)	kWh III	19E-19F	1C8-1C9	17A-17B	Wh
Generated inductive reactive energy III (kvarhL)	kvarhL III	1A0-1A1	1CA-1CB	1EA-1EB	kvarh
Generated inductive reactive energy III (varhL)	kvarhL III	1A2-1A3	1CC-1CD	17C-17D	varh
Generated capacitive reactive energy III (kvarhC)	kvarhC III	1A4-1A5	1CE-1CF	1EC-1ED	kvarh

Tabla 65 (Continuation): Modbus memory Map 1: Energy variables

Map 1					
Parameter	Symbol	Tariff 1	Tariff 2	Total	Units
Generated capacitive reactive energy III (varhC)	kvarhC III	1A6-1A7	1D0-1D1	17E-17F	varh
Generated apparent energy III (kVAh)	kVAh III	1A8-1A9	1D2-1D3	1EE-1EF	kVAh
Generated apparent energy III (VAh)	kVAh III	1AA-1AB	1D4-1D5	180-181	VAh
Generated CO ₂ emissions	KgCO ₂	1B0-1B1	1DA-1DB	186-187	KgCO ₂
Generation Cost	\$	1B2-1B3	1DC-1DD	188-189	\$
Hours per tariff	Hours	1B4-1B5	1DE-1DF	18A-18B	seg

Table 66: Modbus memory Map 2: Energy variables

Map 2					
Parameter	Symbol	Tariff 1	Tariff 2	Total	Units
Consumed active energy III (kWh)	kWh III	105E-105F	1088-1089	10DC-10DD	kWh
Consumed active energy III (Wh)	kWh III	1060-1061	108A-108B	10DE-10DF	Wh
Consumed inductive reactive energy III (kvarhL)	kvarhL III	1062-1063	108C-108D	10E0-10E1	kvarh
Consumed inductive reactive energy III (varhL)	kvarhL III	1064-1065	108E-108F	10E2-10E3	varh
Consumed capacitive reactive energy III (kvarhC)	kvarhC III	1066-1067	1090-1091	10E4-10E5	kvarh
Consumed capacitive reactive energy III (varhC)	kvarhC III	1068-1069	1092-1093	10E6-10E7	varh
Consumed apparent energy III (kVAh)	kVAh III	106A-106B	1094-1095	10E8-10E9	kVAh
Consumed apparent energy III (VAh)	kVAh III	106C-106D	1096-1097	10EA-10EB	VAh
Consumed CO ₂ emissions	KgCO ₂	106E-106F	1098-1099	10EC-10ED	x10
Consumption cost	\$	1070-1071	109A-109B	10EE-10EF	x10
Generated active energy III (kWh)	kWh III	1072-1073	109C-109D	10F0-10F1	kWh
Generated active energy III (Wh)	kWh III	1074-1075	109E-109F	10F2-10F3	Wh
Generated inductive reactive energy III (kvarhL)	kvarhL III	1076-1077	10A0-10A1	10F4-10F5	kvarh
Generated inductive reactive energy III (varhL)	kvarhL III	1078-1079	10A2-10A3	10F6-10F7	varh
Generated capacitive reactive energy III (kvarhC)	kvarhC III	107A-107B	10A4-10A5	10F8-10F9	kvarh
Generated capacitive reactive energy III (varhC)	kvarhC III	107C-107D	10A6-10A7	10FA-10FB	varh
Generated apparent energy III (kVAh)	kVAh III	107E-107F	10A8-10A9	10FC-10FD	kVAh
Generated apparent energy III (VAh)	kVAh III	1080-1081	10AA-10AB	10FE-10EF	VAh
Generated CO ₂ emissions	KgCO ₂	1082-1083	10AC-10AD	1100-1101	x10
Generation Cost	\$	1084-1085	10AE-10AF	1102-1103	x10
Hours per tariff	Hours	1086-1087	10B0-10B1	1104-1105	seg

Table 67: Modbus memory Map 1 and Map 2 (energy variables per phase).

Map 1 and Map 2					
Parameter	Symbol	L1	L2	L3	Units
Consumed active energy (kWh) T1	kWh	1400-1401	1460-1461	14C0-14C1	kWh

Table 67 (Continuation): Modbus memory Map 1 and Map 2 (energy variables per phase)

Map 1 and Map 2					
Parameter	Symbol	L1	L2	L3	Units
Consumed active energy (Wh) T1	kWh	1402-1403	1462-1463	14C2-14C3	Wh
Consumed inductive reactive energy T1 (kvarhL)	kvarhL	1404-1405	1464-1465	14C4-14C5	kvarh
Consumed inductive reactive energy T1 (varhL)	kvarhL	1406-1407	1466-1467	14C6-14C7	varh
Generated active energy T1 (kWh)	kWh	1410-1411	1470-1471	14D0-14D1	kWh
Generated active energy T1 (Wh)	kWh	1412-1413	1472-1473	14D2-14D3	Wh
Generated inductive reactive energy T1 (kvarhL)	kvarhL	1414-1415	1474-1475	14D4-14D5	kvarh
Generated inductive reactive energy T1 (varhL)	kvarhL	1416-1417	1476-1477	14D6-14D7	varh
Consumed active energy (kWh) T2	kWh	1420-1421	1480-1481	14E0-14E1	kWh
Consumed active energy (Wh) T2	kWh	1422-1423	1482-1483	14E2-14E3	Wh
Consumed inductive reactive energy T2 (kvarhL)	kvarhL	1424-1425	1484-1485	14E4-14E5	kvarh
Consumed inductive reactive energy T2 (varhL)	kvarhL	1426-1427	1486-1487	14E6-14E7	varh
Generated active energy T2 (kWh)	kWh	1430-1431	1490-1491	14F0-14F1	kWh
Generated active energy T2 (Wh)	kWh	1432-1433	1492-1493	14F2-14F3	Wh
Generated inductive reactive energy T2 (kvarhL)	kvarhL	1434-1435	1494-1495	14F4-14F5	kvarh
Generated inductive reactive energy T2 (varhL)	kvarhL	1436-1437	1496-1497	14F6-14F7	varh
Consumed active energy (kWh) Total	kWh	1440-1441	14A0-14A1	1500-1501	kWh
Consumed active energy (Wh) Total	kWh	1442-1443	14A2-14A3	1502-1503	Wh
Consumed inductive reactive energy Total (kvarhL)	kvarhL	1444-1445	14A4-14A5	1504-1505	kvarh
Consumed inductive reactive energy Total (varhL)	kvarhL	1446-1447	14A6-14A7	1506-1507	varh
Generated active energy Total (kWh)	kWh	1450-1451	14B0-14B1	1510-1511	kWh
Generated active energy Total (Wh)	kWh	1452-1453	14B2-14B3	1512-1513	Wh
Generated inductive reactive energy Total (kvarhL)	kvarhL	1454-1455	14B4-14B5	1514-1515	kvarh
Generated inductive reactive energy Total (varhL)	kvarhL	1456-1457	14B6-14B7	1516-1517	varh

7.3.3. VOLTAGE AND CURRENT HARMONICS.

For these variables is implemented the **Function 0x03** and **0x04**.

Table 68: Modbus memory Map 1: Voltage Harmonics

Map 1				
Parameter	Voltage L1	Voltage L2	Voltage L3	Units
Fundamental Harm.	2AE-2AF	2CC-2CD	2EA-2EB	V x 10
2nd Order harmonic	2B0-2B1	2CE-2CF	2EC-2ED	% x 10
3rd Order harmonic	2B2-2B3	2D0-2D1	2EE-2EF	% x 10
4th Order harmonic	2B4-2B5	2D2-2D3	2F0-2F1	% x 10

Table 68 (Continuation): Modbus memory Map 1: Voltage Harmonics

Map 1				
Parameter	Voltage L1	Voltage L2	Voltage L3	Units
5th Order harmonic	2B6-2B7	2D4-2D5	2F2-2F3	% x 10
6th Order harmonic	2B8-2B9	2D6-2D7	2F4-2F5	% x 10
7th Order harmonic	2BA-2BB	2D8-2D9	2F6-2F7	% x 10
8th Order harmonic	2BC-2BD	2DA-2DB	2F8-2F9	% x 10
9th Order harmonic	2BE-2BF	2DC-2DD	2FA-2FB	% x 10
10th Order harmonic	2C0-2C1	2DE-2DF	2FC-2FD	% x 10
11th Order harmonic	2C2-2C3	2E0-2E1	2FE-2FF	% x 10
12th Order harmonic	2C4-2C5	2E2-2E3	300-301	% x 10
13th Order harmonic	2C6-2C7	2E4-2E5	302-303	% x 10
14th Order harmonic	2C8-2C9	2E6-2E7	304-305	% x 10
15th Order harmonic	2CA-2CB	2E8-2E9	306-307	% x 10
16th Order harmonic	308-309	328-329	348-349	% x 10
17th Order harmonic	30A-30B	32A-32B	34A-34B	% x 10
18th Order harmonic	30C-30D	32C-32D	34C-34D	% x 10
19th Order harmonic	30E-30F	32E-32F	34E-34F	% x 10
20th Order harmonic	310-311	330-331	350-351	% x 10
21st Order harmonic	312-313	332-333	352-353	% x 10
22nd Order harmonic	314-315	334-335	354-355	% x 10
23rd Order harmonic	316-317	336-337	356-357	% x 10
24th Order harmonic	318-319	338-339	358-359	% x 10
25th Order harmonic	31A-31B	33A-33B	35A-35B	% x 10
26th Order harmonic	31C-31D	33C-33D	35C-35D	% x 10
27th Order harmonic	31E-31F	33E-33F	35E-35F	% x 10
28th Order harmonic	320-321	340-341	360-361	% x 10
29th Order harmonic	322-323	342-343	362-363	% x 10
30th Order harmonic	324-325	344-345	364-365	% x 10
31st Order harmonic	326-327	346-347	366-367	% x 10

Table 69: Modbus memory Map 2: Voltage Harmonics

Map 2				
Parameter	Voltage L1	Voltage L2	Voltage L3	Units
Fundamental Harm.	1A28-1A29	1A48-1A49	1A68-1A69	V x 10
2nd Order harmonic	1A2A	1A4A	1A6A	% x 10
3rd Order harmonic	1A2B	1A4B	1A6B	% x 10
4th Order harmonic	1A2C	1A4C	1A6C	% x 10
5th Order harmonic	1A2D	1A4D	1A6D	% x 10
6th Order harmonic	1A2E	1A4E	1A6E	% x 10
7th Order harmonic	1A2F	1A4F	1A6F	% x 10
8th Order harmonic	1A30	1A50	1A70	% x 10
9th Order harmonic	1A31	1A51	1A71	% x 10
10th Order harmonic	1A32	1A52	1A72	% x 10
11th Order harmonic	1A33	1A53	1A73	% x 10
12th Order harmonic	1A34	1A54	1A74	% x 10

Table 69 (Continuation): Modbus memory Map 2: Voltage Harmonics

Map 2				
Parameter	Voltage L1	Voltage L2	Voltage L3	Units
13th Order harmonic	1A35	1A55	1A75	% x 10
14th Order harmonic	1A36	1A56	1A76	% x 10
15th Order harmonic	1A37	1A57	1A77	% x 10
16th Order harmonic	1A38	1A58	1A78	% x 10
17th Order harmonic	1A39	1A59	1A79	% x 10
18th Order harmonic	1A3A	1A5A	1A7A	% x 10
19th Order harmonic	1A3B	1A5B	1A7B	% x 10
20th Order harmonic	1A3C	1A5C	1A7C	% x 10
21st Order harmonic	1A3D	1A5D	1A7D	% x 10
22nd Order harmonic	1A3E	1A5E	1A7E	% x 10
23rd Order harmonic	1A3F	1A5F	1A7F	% x 10
24th Order harmonic	1A40	1A60	1A80	% x 10
25th Order harmonic	1A41	1A61	1A81	% x 10
26th Order harmonic	1A42	1A62	1A82	% x 10
27th Order harmonic	1A43	1A63	1A83	% x 10
28th Order harmonic	1A44	1A64	1A84	% x 10
29th Order harmonic	1A45	1A65	1A85	% x 10
30th Order harmonic	1A46	1A66	1A86	% x 10
31st Order harmonic	1A47	1A67	1A87	% x 10

Table 70: Modbus memory Map 1: Current Harmonics

Map 1				
Parameter	Current L1	Current L2	Current L3	Units
Fundamental Harm.	1F4-1F5	212-213	230-231	mA x 10
2nd Order harmonic	1F6-1F7	214-215	232-233	% x 10
3rd Order harmonic	1F8-1F9	216-217	234-235	% x 10
4th Order harmonic	1FA-1FB	218-219	236-237	% x 10
5th Order harmonic	1FC-1FD	21A-21B	238-239	% x 10
6th Order harmonic	1FE-1FF	21C-21D	23A-23B	% x 10
7th Order harmonic	200-201	21E-21F	23C-23D	% x 10
8th Order harmonic	202-203	220-221	23E-23F	% x 10
9th Order harmonic	204-205	222-223	240-241	% x 10
10th Order harmonic	206-207	224-225	242-243	% x 10
11th Order harmonic	208-209	226-227	244-245	% x 10
12th Order harmonic	20A-20B	228-229	246-247	% x 10
13th Order harmonic	20C-20D	22A-22B	248-249	% x 10
14th Order harmonic	20E-20F	22C-22D	24A-24B	% x 10
15th Order harmonic	210-211	22E-22F	24C-24D	% x 10
16th Order harmonic	24E-24F	26E-26F	28E-28F	% x 10
17th Order harmonic	250-251	270-271	290-291	% x 10
18th Order harmonic	252-253	272-273	292-293	% x 10
19th Order harmonic	254-255	274-275	294-295	% x 10
20th Order harmonic	256-257	276-277	296-297	% x 10

Table 70 (Continuation): Modbus memory Map 1: Current Harmonics

Map 1				
Parameter	Current L1	Current L2	Current L3	Units
21st Order harmonic	258-259	278-279	298-299	% x 10
22nd Order harmonic	25A-25B	27A-27B	29A-29B	% x 10
23rd Order harmonic	25C-25D	27C-27D	29C-29D	% x 10
24th Order harmonic	25E-25F	27E-27F	29E-29F	% x 10
25th Order harmonic	260-261	280-281	2A0-2A1	% x 10
26th Order harmonic	262-263	282-283	2A2-2A3	% x 10
27th Order harmonic	264-265	284-285	2A4-2A5	% x 10
28th Order harmonic	266-267	286-287	2A6-2A7	% x 10
29th Order harmonic	268-269	288-289	2A8-2A9	% x 10
30th Order harmonic	26A-26B	28A-28B	2AA-2AB	% x 10
31st Order harmonic	26C-26D	28C-28D	2AC-2AD	% x 10

Table 71: Modbus memory Map 2: Current Harmonics

Map 2				
Parameter	Current L1	Current L2	Current L3	Units
Fundamental Harm.	1A88-1A89	1AA8-1AA9	1AC8-1AC9	mA x 10
2nd Order harmonic	1A8A	1AAA	1ACA	% x 10
3rd Order harmonic	1A8B	1AAB	1ACB	% x 10
4th Order harmonic	1A8C	1AAC	1ACC	% x 10
5th Order harmonic	1A8D	1AAD	1ACD	% x 10
6th Order harmonic	1A8E	1AAE	1ACE	% x 10
7th Order harmonic	1A8F	1AAF	1ACF	% x 10
8th Order harmonic	1A90	1AB0	1AD0	% x 10
9th Order harmonic	1A91	1AB1	1AD1	% x 10
10th Order harmonic	1A92	1AB2	1AD2	% x 10
11th Order harmonic	1A93	1AB3	1AD3	% x 10
12th Order harmonic	1A94	1AB4	1AD4	% x 10
13th Order harmonic	1A95	1AB5	1AD5	% x 10
14th Order harmonic	1A96	1AB6	1AD6	% x 10
15th Order harmonic	1A97	1AB7	1AD7	% x 10
16th Order harmonic	1A98	1AB8	1AD8	% x 10
17th Order harmonic	1A99	1AB9	1AD9	% x 10
18th Order harmonic	1A9A	1ABA	1ADA	% x 10
19th Order harmonic	1A9B	1ABB	1ADB	% x 10
20th Order harmonic	1A9C	1ABC	1ADC	% x 10
21st Order harmonic	1A9D	1ABD	1ADD	% x 10
22nd Order harmonic	1A9E	1ABE	1ADE	% x 10
23rd Order harmonic	1A9F	1ABF	1ADF	% x 10
24th Order harmonic	1AA0	1AC0	1AE0	% x 10
25th Order harmonic	1AA1	1AC1	1AE1	% x 10
26th Order harmonic	1AA2	1AC2	1AE2	% x 10
27th Order harmonic	1AA3	1AC3	1AE3	% x 10

Table 71 (Continuation): Modbus memory Map 2: Current Harmonics

Map 2				
Parameter	Current L1	Current L2	Current L3	Units
28th Order harmonic	1AA4	1AC4	1AE4	% x 10
29th Order harmonic	1AA5	1AC5	1AE4	% x 10
30th Order harmonic	1AA6	1AC6	1AE6	% x 10
31st Order harmonic	1AA7	1AC7	1AE7	% x 10

7.3.4. DELETING PARAMETERS.

The **Function 0x05** is implemented for these variables.

Table 72: Modbus memory map: Deleting parameters.

Parameters	Address	Valid data margin
Deleting maximum values	849	FF00
Deleting minimum values	84A	FF00
Maximum demand initialization	852	FF00
Deleting the hour counters (Tariff 1)	837	FF00
Deleting the hour counters (Tariff 2)	83A	FF00
Deleting energies per phase (L1, L2, L3) and three-phase energies	874	FF00
Deleting three-phase energies	834	FF00
Deleting energies per phase (L1, L2, L3)	873	FF00
Deleting energies per phase (L1)	870	FF00
Deleting energies per phase (L2)	871	FF00
Deleting energies per phase (L3)	872	FF00
Deleting all of the previous parameters	898	FF00
Deleting the digital input pulse counter	884	FF00

7.3.5. POWER STATUS

The **function 0x04** is implemented for this variable.

This variable indicates the quadrant in which the device is operating.

Table 73: Modbus memory map: Power status

Power status		
Variable	Address	Default value
Power status	7D1	-

The variable format is shown in **Table 74**:

Table 74: Variable format: Power status.

Bit 7	Bit 6	Bit 5	Bit 4	Bit 3	Bit 2	Bit 1	Bit 0
0	0	0	0	1: Capacitive	1: Inductive	1: Generated	1: Consumed

7.3.6. DETECTION OF INCORRECT DIRECTION OF ROTATION

The function **0x04** is implemented for this variable.

This variable indicates whether an incorrect direction of rotation has been detected in the voltages.

Table 75: Modbus memory map: Detection of incorrect direction of rotation.

Detection of incorrect direction of rotation		
Variable	Address	Value
Detection of incorrect direction of rotation	7D5	0: No fault has been detected 1: Fault detected

7.3.7. DEVICE SERIAL NUMBER

The function **0x04** is implemented for this variable.

Table 76: Modbus memory map: Device serial number

Device serial number	
Variable	Address
Serial number	5AA - 5AB - 5AC - 5AD - 5AE - 5AF - 5B0

7.3.8. DIGITAL INPUT: PULSE COUNTER

The functions **0x04** and **0x10** are implemented for this variable.

If the Digital Input has been configured as Pulse Counter, the value of the counter is displayed in this variable.

Table 77: Modbus memory map: Pulse counter.

Pulse counter		
Variable	Format	Address
Digital input pulse counter	Uint [64]	4E23 - 4E24 - 4E25 - 4E26

7.3.9. DEVICE CONFIGURATION VARIABLES.

The functions **0x04** and **0x10** are implemented for this variable.

The device's Modbus function does not check whether the variables recorded are within the correct margins, they are only checked when they are read from the EEPROM. So if any parameter is recorded with an incorrect value the device will be configured with its default value.

The Modbus configuration will not take effect until the device is reset.

7.3.9.1. Transformation ratios.

Table 78: Modbus memory map: Transformation ratios.

Transformation ratios			
Configuration variable ⁽⁷⁾	Address	Valid data margin	Default value
Voltage primary	2710 - 2711	1 - 599999	1
Voltage secondary	2712	1 - 999	1
Current primary ⁽⁸⁾	2713	1 - 10000	5
Current secondary ⁽⁹⁾	2714	0: .../1A 1: .../5 A	1

⁽⁷⁾ Voltage ratio x Current ratio ≤ 300000.
Voltage ratio ≤ 1000.

⁽⁸⁾ Configurable parameter in the models: CVM-E3-MINI-ITF, CVM-E3-MINI-ITF-WiEth, CVM-E3-MINI-MC and CVM-E3-MINI-MC-WiEth.

⁽⁹⁾ Configurable parameter in the models: CVM-E3-MINI-ITF and CVM-E3-MINI-ITF-WiEth.

Note: The ratio is between the primary and the secondary.

Note: The 5 registers must be written or read at once (as a group); otherwise, the system will respond with an error.

7.3.9.2. Flex sensor type (Models CVM-E3-MINI-FLEX and CVM-E3-MINI-FLEX-WiEth)

Table 79: Modbus memory map: Flex sensor type.

Tipo de sensor Flex			
Configuration variable	Address	Valid data margin	Default value
Flex sensor	2756	0: 100 uV/A 1: 76 uV/A	0

7.3.9.3. Number of quadrants

Table 80: Modbus memory map: Number of quadrants

Numberof quadrants			
Configuration variable	Address	Valid data margin	Default value
Number of quadrants	2B64	0: 4 quadrants 1: 2 quadrants	0

7.3.9.4. Measurement convention

Table 81: Modbus memory map: Measurement convention.

Measurement convention			
Configuration variable	Address	Valid data margin	Default value
Measurement convention	2B86	0: Circutor 1: IEC 2: IEEE	0

7.3.9.5. Measurement system

Table 82: Modbus memory map: Measurement system

Measurement system			
Configuration variable	Address	Valid data margin	Default value
Measurement system	2B5C	0: 4-3Ph Three-phase network with 4 wires. 1: 3-3Ph Three-phase network with 3 wires. 2: 3-3r0i Three-phase network with 3 wires, Aron. ⁽¹⁰⁾ 3: 3-2Ph Two-phase network with 3 wires. 4: 2-2Ph Single-phase network with 2 wires, phase-to-phase. 5: 2-1Ph Single-phase network with 2 wires, phase-to-neutral.	0

⁽¹⁰⁾ Option not available for the CVM-E3-MINI-FLEX and CVM-E3-MINI-FLEX-WiEth models.

7.3.9.6. Maximum demand

Table 83: Modbus memory map: Maximum demand

Maximum demand			
Configuration variable	Address	Valid data margin	Default value
Integration period	274C	0: The maximum demand will not be calculated 1 - 60 minutes	0

7.3.9.7. Display backlight

Table 84: Modbus memory map: Backlight

Backlight			
Configuration variable	Address	Valid data margin	Default value
Backlight	2B5E	1 - 999 seconds	300 s

7.3.9.8. Activating the harmonics display screen

Table 85: Modbus memory map: Display of harmonics

Display of harmonics			
Configuration variable	Address	Valid data margin	Default value
Display of harmonics	2B62	0: No 1: Yes	0

7.3.9.9. CO₂ consumption and generation emissions.

Table 86: Modbus memory map: CO₂ consumption and generation emissions.

CO ₂ emissions			
Configuration variable ⁽¹¹⁾	Address	Valid data margin	Default value
Tariff 1 consumption emissions ratio	2724	0 - 1.9999	0
Tariff 2 consumption emissions ratio	2725	0 - 1.9999	0
Tariff 1 generation emissions ratio	2728	0 - 1.9999	0
Tariff 2 generation emissions ratio	2729	0 - 1.9999	0

⁽¹¹⁾ They have 1 decimal place.

7.3.9.10. Cost of energy consumption and generation.

Table 87: Modbus memory map: Cost of energy consumption and generation.

Cost per kWh			
Configuration variable ⁽¹²⁾	Address	Valid data margin	Default value
Cost per kWh of tariff 1 consumption	272C	0 - 1.9999	0
Cost per kWh of tariff 2 consumption	272D	0 - 1.9999	0
Cost per kWh of tariff 1 generation	2730	0 - 1.9999	0
Cost per kWh of tariff 2 generation	2731	0 - 1.9999	0

⁽¹²⁾ They have 1 decimal place.

7.3.9.11. Programming Digital Output T1

Note: The *CVM-E3-MINI-xxx-WiEth* models do not have a Digital Output, so the alarm only triggers the activation of the **ALARM / ENERGY PULSES LED**.

Table 88: Modbus memory map: Programming Digital Output T1 (Alarm)

Programming Digital Output : Alarm			
Configuration variable	Address	Valid data margin	Default value
Maximum value	2AF8-2AF9	depending on the variable	0
Minimum value	2AFA-2AFB	depending on the variable	0
Variable code	2AFC	Table 38 and Table 39	0
Connection delay	2AFD	0 - 9999 seconds	0
Hysteresis	2AFE	0 - 99 %	0
Latch	2AFF	0 : No 1 : Yes	0
Latch time ⁽¹³⁾	2B02	0 - 600 seconds	0
Disconnection delay	2B00	0 - 9999 seconds	0
Contacts status	2B01	0 : Normally open 1 : Normally closed	0

⁽¹⁸⁾ The **latch time** is the time in seconds when the alarm will be latched. After this time, if the alarm condition has cleared, the disconnection delay is activated. If a 0 is programmed, the alarm remains latched and can only be unlatched manually.

Table 89: Modbus memory map: Programming Digital Output T1 (pulses output)

Programming Digital Output : Pulses output			
Configuration variable	Address	Valid data margin	Default value
Kilowatts per impulse	2B20-2B21	0.001 - 999.99 kWh	1.00 kWh
Variable code	2AFC	Table 40	0
Pulse width	2B22	30 - 500 ms	100 ms

7.3.9.12. Digital inputs (Models CVM-E3-MINI-xxx)

The operation of the input as a pulse counter is independent of the programming of the digital input, that is, the device can be used as a logic input or tariff selection at the same time as a pulse counter.

Table 90: Modbus memory map: Configuration of digital inputs.

Configuration variable	Address	Valid data margin	Default value
Operating mode	2B66	0 : Tariff 1 : Logic state	0
Pulse counter: Weight ⁽¹⁴⁾	2B67	0 - 65535	1
Pulse counter: Pulse width ⁽¹⁴⁾	2B68	10 - 10000 ms	30

⁽¹⁴⁾ In order for the digital input to function as a **pulse counter**, this parameter must be programmed with a value > 0.

We can also read the status of the digital inputs when they are in logic mode:

The **Function 0x04** is implemented for this variable.

Table 91: Modbus memory map: Status of the digital inputs (Logic state mode)

Status of digital inputs		
Variable	Address	Default value
Status of digital inputs	4E20	-

The variable format is shown in **Table 92**:

Table 92: Variable format: Status of digital inputs.

Bit 7	Bit 6	Bit 5	Bit 4	Bit 3	Bit 2	Bit 1	Bit 0
0	0	0	0	0	0	0	Input 1 0: OFF- 1: ON

7.3.9.13. Tariff selection (Models CVM-E3-MINI-xxx-WiEth)

Table 93: Modbus memory map: Tariff selection configuration.

Configuration variable	Address	Valid data margin	Default value
Tariff selection	2B66	0: Tariff 1 1: Tariff 2	0

7.3.9.14. Digital outputs (Models CVM-E3-MINI-xxx)

Reading the status of the digital outputs.

The **Function 0x04** is implemented for this variable.

Table 94: Modbus memory map: Status of the digital outputs

Status of the digital outputs		
Variable	Address	Default value
Status of the digital outputs	4E21	-

The variable format is shown in **Table 95**:

Table 95: Variable format: Status of the digital outputs.

Bit 7	Bit 6	Bit 5	Bit 4	Bit 3	Bit 2	Bit 1	Bit 0
0	0	0	0	0	0	0	Output 1 0: OFF 1: ON

7.3.9.15. Communications (Models CVM-E3-MINI-xxx)

Table 96: Modbus memory map: Communications

Communications			
Configuration variable	Address	Valid data margin	Default value
Protocol	2742	0 : Modbus 1: Bacnet	0
Modbus and BACnet: Peripheral number	2743	0 - 255	1
Modbus : Baud rate	2744	0: 9600 - 1:19200 - 2: 38400 ⁽¹⁵⁾ - 3: 57600 ⁽¹⁵⁾ - 4: 115200 ⁽¹⁵⁾	1
Modbus : Parity	2745	0: No parity 1: Odd parity 2: Even parity	0
Modbus : Data bits	2746	0 : 8 bits 1: 7 bits	0
Modbus : Stop bits	2747	0 : 1 stop bit 1: 2 stop bits	0
BACnet: Device ID	2EE0- 2EE1	0- 99999	1

Table 96 (Continuation): Modbus memory map: Communications

Communications			
Configuration variable	Address	Valid data margin	Default value
BACnet: MAC	2EE2	0- 127	2
BACnet: Baud rate	2744	0: 9600 - 1:19200 - 2: 38400 ⁽¹⁵⁾ - 3: 57600 ⁽¹⁵⁾ - 4: 115200 ⁽¹⁵⁾	1

⁽¹⁵⁾ Available on devices with software version v2.xx.

7.3.9.16. Password configuration

These variables allow you to lock or unlock access to the programming menu, and also allow you to change the password code. The password code may only be changed through this command. The device does not need you to enter the old password in order for it to record the new one; it records the new one directly without any verification.

Table 97: Modbus memory map: Password configuration

Password			
Configuration variable	Address	Valid data margin	Default value
Password value ⁽¹⁶⁾	2B70	0 - 9999	1234
Lock-Unlock	2B71	0: Unlock 1: Lock	0

⁽¹⁶⁾ The password value is read and written in hexadecimal.

7.4.- BACnet PROTOCOL

BACnet is a communications protocol for Building Automation and Control NETWORKS. This protocol replaces the proprietary communications of each device, making it a set of common communication rules that enables the complete integration of the building automation and control devices of different manufacturers.

The device features **BACnet** MS/TP communications, following the specifications of ANSI/ASHRAE 135 (ISO 16484-5).

Using a RS485 connection, the device can connect to a BACnet and include all of the objects and services defined in the attached PICS map (Protocol Implementation Conformance Statement). ("**7.4.1. PICS MAP**")

The default speed is 19200 bps and the MAC is 2 (node number), and can be changed on the configuration screen or by entering the BaudRate and MAC_Address variables. The identifier (Device_ID) can be changed on the configuration screen using the writing property over the variable or through the Device_ID variable.

Another option is to overwrite the Object_Name in the Device object:

- #Baud x – where x can be: 9600, 19200, 38400
- #MAC x – where x can be: 0 ... 127
- #ID x – where x can be: 0 ... 99999

For further information on the protocol: www.bacnet.org.

7.4.1.- MAPA PICS

PICS

Vendor Name: CIRCUTOR
 Product Name: CVM-E3-MINI
 Product Model Number: 837
 Application Software Version: 1.0
 Firmware Revision: 0.7.1
 BACnet Protocol Revision: 10

Product Description:

Electrical energy meter

BACnet Standardized Device Profile (Annex L)

x	BACnet Application Specific Controller (B-ASC)
---	--

List all BACnet Interoperability Building supported (see Annex K in BACnet Addendum 135d):

DS-RP-B Read Property DS-WP-B Write Property DS-RPM-B Read Property Multiple DM-DDB-B Dynamic Device Binding DM-DOB-B Dynamic Object Binding DM-DCC-B Device Communication Control DM-RD-B Reinitialize Device
--

Which of the following device binding methods does the product support? (check one or more)

x	Recive Who-Is, send I-Am (BIBB DM-DDB-B)
x	Recive Who-Has, send I-Have (BIBB DM-DOB-B)

Standard Object Types Supported:

Analog Input Object Type

1. Dynamically creatable using BACnet's CreateObject service?	No	
2. Dynamically deletable using BACnet's DeleteObject service?	No	
3. List of optional properties supported:	max_pres_value	min_pres_value
4. List of all properties that are writable where not otherw is a required by this standard		
5. List of proprietary properties:		
6. List of any property value range restrictions:		

Properly Identifier

Object_Name	max 32 characters
-------------	-------------------

DESCRIPTION		SYMBOL	ID OBJECTS	OBJECT NAME	UNITS
Tensión fase-neutro	Voltage phase to neutral	V 1	A10	Ph2NU1	V
Corriente	Current	A 1	A11	Ph1Current	A
Potencia activa	Active power	kW 1	A12	ActPwrPh1	kW
Potencia reactiva	Reactive power	kvar 1	A13	ReactPwrPh1	kvar
Factor de potencia	Power factor	PF 1	A14	PwrFactPh1	PF
Tensión fase-neutro	Voltage phase to neutral	V 2	A15	Ph2NU2	V
Corriente	Current	A 2	A16	Ph2Current	A
Potencia activa	Active power	kW 2	A17	ActPwrPh2	kW
Potencia reactiva	Reactive power	kvar 2	A18	ReactPwrPh2	kvar

DESCRIPTION		SYMBOL	ID OBJECTS	OBJECT NAME	UNITS
Factor de potencia	Power factor	PF 2	AI9	PwrFactPh2	PF
Tensión fase-neutro	Voltage phase to neutral	V 3	AI10	Ph2NU3	V
Corriente	Current	A 3	AI11	Ph3Current	A
Potencia activa	Active power	kW 3	AI12	ActPwrPh3	kW
Potencia reactiva	Reactive power	kvar 3	AI13	ReactPwrPh3	kvar
Factor de potencia	Power factor	PF 3	AI14	PwrFactPh3	PF
Potencia activa trifásica	Three phase active power	kW III	AI15	ActPwOn3Ph	kW
Potencia inductiva trifásica	Three phase reactive inductive power	kvarL III	AI16	InductPwOn3Ph	kvarL
Potencia capacitiva trifásica	Three phase capacitive inductive power	kvarC III	AI17	CapPwOn3Ph	kvarC
Cos φ trifásico	Three phase cos φ	Cos φ III	AI18	Cosphi	Cos φ
Factor de potencia trifásico	Three phase power factor	PFIII	AI19	PwFactOn3Ph	PF
Frecuencia (L2)	Frequency	Hz	AI20	Frequency	Hz
Tensión fase-fase	Voltage phase to phase	V12	AI21	Ph2PhU12	V
Tensión fase-fase	Voltage phase to phase	V23	AI22	Ph2PhU23	V
Tensión fase-fase	Voltage phase to phase	V31	AI23	Ph2PhU31	V
%THD V	%THD V	%THD V1	AI24	THDVal_U1	%THD
%THD V	%THD V	%THD V2	AI25	THDVal_U2	%THD
%THD V	%THD V	%THD V3	AI26	THDVal_U3	%THD
%THD A	%THD A	%THD A1	AI27	THDVal_I1	%THD
%THD A	%THD A	%THD A2	AI28	THDVal_I2	%THD
%THD A	%THD A	%THD A3	AI29	THDVal_I3	%THD
Energía activa	Active energy	kW·h III	AI30	ActEnergy	kW·h
Energía reactiva inductiva	Reactive inductive energy	kvarL·h III	AI31	InductEnergy	kvarL·h
Energía reactiva capacitiva	Reactive capacitive energy	kvarC·h III	AI32	CapEnergy	kvarC·h
Energía Aparente trifásica	Three phase aparent energy	kVA·h III	AI33	AppEnergy	kVA·h
Energía activa generada	Three phase generated active energy	kW·h III (-)	AI34	ActEnergy_exp	kW·h
Energía inductiva generada	Three phase generated reactive inductive energy	kvarL·h III (-)	AI35	IndEnergy_exp	kvarL·h
Energía capacitiva generada	Three phase generated reactive capacitive energy	kvarC·h III(-)	AI36	CapEnergy_exp	kvarC·h
Energía aparente generada	Three phase generated aparent energy	kVA·h III (-)	AI37	AppEnergy_exp	kVA·h
Corriente trifásica (media)	Three phase average current	I_AVG	AI38	AvgValCurr3Ph	I_AVG
Potencia aparente L1	Aparent power L1	kVA	AI40	AppPwrPh1	kVA
Potencia aparente L2	Aparent power L2	kVA	AI41	AppPwrPh2	kVA
Potencia aparente L3	Aparent power L3	kVA	AI42	AppPwrPh3	kVA
Potencia aparente trifásica	Three phase aparent power	kVAIII	AI43	AppPw3Ph	kVA
Máxima demanda I1	Maximum demand I1	Md (A1)	AI44	MaxDemand_A1	A
Máxima demanda I2	Maximum demand I2	Md(A2)	AI45	MaxDemand_A2	A

DESCRIPTION		SYMBOL	ID OBJECTS	OBJECT NAME	UNITS
Máxima demanda I3	Maximum demand I3	Md(A3)	AI46	MaxDemand_A3	A
Máxima demanda A	Maximum demand A	A III	AI47	MaxDemand_A	A
Máxima demanda kW	Maximum demand kW	kW III	AI48	MaxDemand_kW	kW
Máxima demanda kVA	Maximum demand kVA	kVA III	AI49	MaxDemand_kVA	kVA

Analog Value Object Type

1. Dynamically creatable using BACnet's CreateObject service?		No
2. Dynamically deletable using BACnet's DeleteObject service?		No
3. List of optional properties supported:		
4. List of all properties that are writable where not otherwise required by this standard		
5. List of proprietary properties:		
Property Identifier	Property Datatype	Meaning
5. List of object identifiers and their meaning in this device		
Object ID	Object Name	Description
AV1	MAC_Address	MAC
AV2	BaudRate	BAUD RATE
AV3	Device_ID	DEVICE ID

Device Object Type

1. Dynamically creatable using BACnet's CreateObject service?		No
2. Dynamically deletable using BACnet's DeleteObject service?		No
3. List of optional properties supported:		Description, Protocolo_Conformance_Class
4. List of all properties that are writable where not otherwise required by this standard		
Object_Name Max_Master Max_Info_Frames Object_Identifier		
5. List of proprietary properties:		
5. List of any property value range restrictions		
Property Identifier	Restrictions	
Object_Name	< 32 bytes	
Object_Identifier	Device Type only	
Number_Of_APDU_Retries	0-255	
APDU_Timeout	0-65535 milliseconds	
Vendor_Identifier	0-65535	

Data Link Layer Options (check all that supported):

X	MS/TP master (Clause 9), baud rate(s): 9.6, 19.2kB/s
---	--

Character Sets Supported (check all that apply):

Indicating support for multiple character set does not imply that they can all be supported simultaneously.

X	ANSI X3.4
---	-----------

8.- CVM-E3-MINI-xxx-WiEth : COMMUNICATIONS

CVM-E3-MINI-xxx-WiEth devices include Ethernet, Wi-Fi and Bluetooth® communications.

Communications can be set up via the device's settings web page ("**8.5.- CONFIGURATION WEB PAGE**") or via the device's display, see "**5.5. ETHERNET - WI-FI - BLUETOOTH® COMMUNICATIONS SCREENS (CVM-E3-MINI-xxx-WiEth models)**".

The Modbus map in Section "**7.3. MODBUS COMMANDS**" is also valid for CVM-E3-MINI-xxx-WiEth devices using the Modbus TCP protocol.

8.1.- USAGE ENVIRONMENT AND HEALTH

Wireless communications emit radio frequency electromagnetic energy, like other radio devices.

Because wireless communications operate under the guidelines found in radio frequency standards and recommendations, they are safe for users to use.

In some settings and situations the use of wireless communications may be restricted by the building's owner or representatives of the organisation.

These may include:

- ✓ Use of wireless connections on board aircraft, in hospitals or near service stations, blasting areas, medical implants or electronic medical devices implanted in the human body (pacemakers, etc.).
- ✓ In any other setting where the risk of interference with other devices or services is a hazard.

If you are not sure of the applicable usage policy for wireless devices in a specific organisation (airport, hospital, etc.) we recommend requesting permission to use wireless communications.

8.2.- Wi-Fi COMMUNICATIONS

Wi-Fi is one of the most widely-used wireless technologies today, used to connect electronic devices and exchange information between them without a physical connection.

The CVM-E3-MINI-xxx-WiEth models has Wi-Fi communications over the 2.4 GHz band, in accordance with the IEEE 802.11b, IEEE 802.11g and IEEE 802.11n standards.

Note: *To maintain the device's IP address and not lose Wi-Fi communications, we recommend to set up the router in such a way as to provide CVM-E3-MINI-xxx-WiEth devices with a fixed IP address that is indexed to the device's MAC address.*

8.3.- Bluetooth® COMMUNICATIONS

The device includes Bluetooth® wireless communications.

Bluetooth® is a short-range wireless technology that allows devices to exchange data within a range of approximately 10 metres.

8.4.- MOBILE APP

The **MyConfig** mobile app, which can be used to set up Wi-Fi and Ethernet communications via Bluetooth®, can be downloaded free of charge from Google Play (Android).

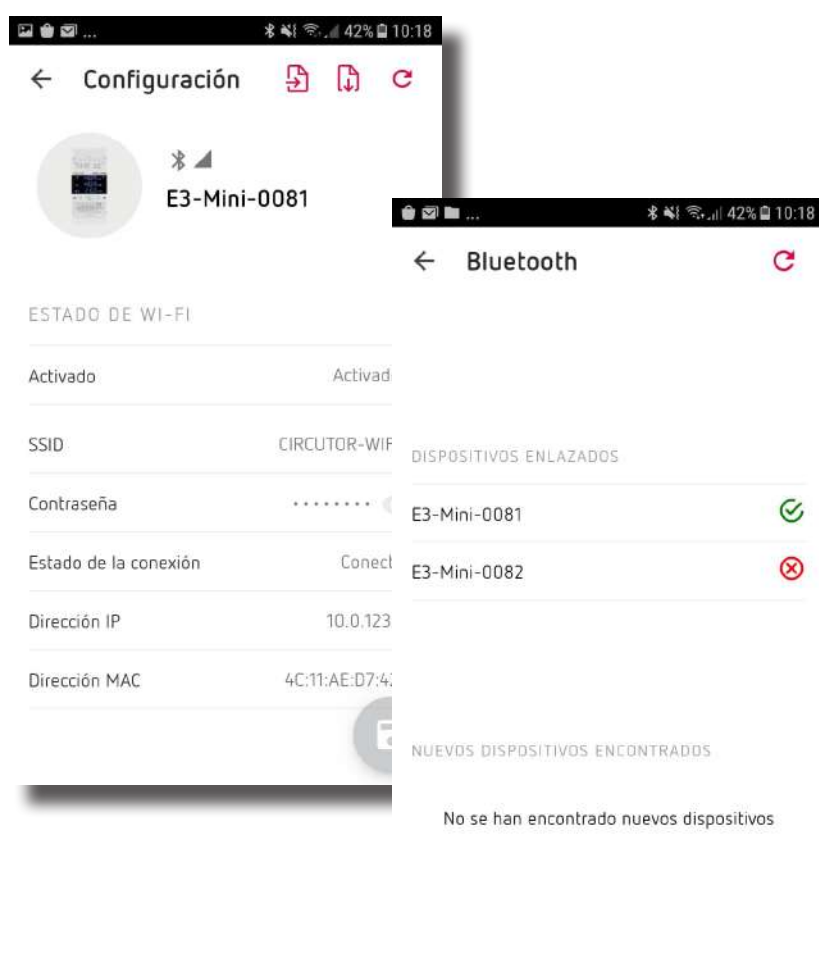

Figure 34: MyConfig mobile app.

Once Bluetooth® is on, scan for devices. The list will show a device named **E3-Mini-XXXX**, where XXXX is the last 4 digits of the serial number of the device.

Pair the device via Bluetooth® by pressing **"Start"**. The PIN corresponds to the last 6 digits of the serial number (S/N) of the device.

8.5.- CONFIGURATION WEB PAGE

To access the internal configuration web page, the IP address of the device must be entered in the web browser.

The IP address of the device is shown on the following screens: **“5.5.2 ETHERNET COMMUNICATIONS: IP ADDRESS”**, for Ethernet connections, or **“5.5.6. WI-FI COMMUNICATIONS: IP ADDRESS”**, for Wi-Fi connections.

To access the configuration website, open the screen shown in **Figure 35**, and enter the Username and Password. The default values are shown in **Table 98**.

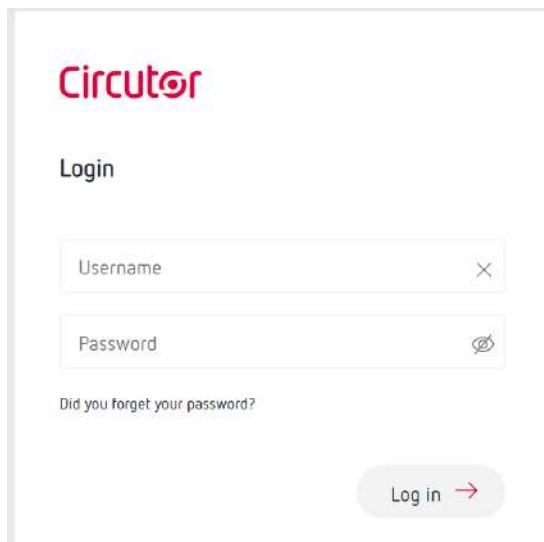

Figure 35: Accessing the configuration website..

Table 98: Accessing the configuration website..

Accessing the configuration website.	
Username	admin
Password	circutor

If you have forgotten the access password, click on the option **Did you forget your password?**, to be able to change the password using the serial number of the device.

On the device's web page you can:

- ✓ View information on the device and the communications settings for Ethernet, Wi-Fi and Bluetooth on the **Device Info** screen (Figure 36).

CVM-E3-MINI-WiEth	
Device Info	Device Info
Communications	
Firmware	
Device Variables	
Serial Number	21851543050151
Manufacturing Date	Year: 2018 Week: 51
Model	CVM-E3-MINI-ITF-WiEth
Communications Firmware Version	1.0.2
Measure Firmware Version	1.17
Ethernet Communications	
DHCP	Enabled
Ethernet Link Status	Connected
Ethernet IP	10.0.120.32
Ethernet Netmask	255.255.255.0
Ethernet Gateway	10.0.120.254
Ethernet MAC	24:6F:28:D4:28:AF
Wi-Fi Communications	
Wi-Fi	Enabled
Wi-Fi Status	75% Connected
Wi-Fi Name (SSID)	Pruebas
Wi-Fi IP	10.0.123.15
Wi-Fi Netmask	255.255.255.0
Wi-Fi Gateway	10.0.123.254
Wi-Fi MAC	24:6F:28:D4:28:AC
Bluetooth	
Bluetooth Name	E3-Mini-0151

Figure 36: Web page: Device Info.

- ✓ Edit the settings for Ethernet and Wi-Fi communications on the **Communications** screen (Figure 37).

Circutor CVM-E3-MINI-WiEth

Device Info

Communications

Firmware

Ethernet Communications

DHCP

Ethernet IP 10.0.120.32

Ethernet Netmask 255.255.255.0

Ethernet Gateway 10.0.120.254

Save

Wi-Fi Communications

Wi-Fi

Wi-Fi Name (SSID) Pruebas

Wi-Fi Password

Save

Figure 37: Web page: Communications.

- ✓ Update the communications firmware on the **Firmware** screen (Figure 38).

Circutor CVM-E3-MINI-WiEth

Device Info

Communications

Firmware

Upgrade Communications Firmware Version

Current Communications Firmware Version 1.0.2

Upgrade

Figure 38: Web page: Firmware.

9.- TECHNICAL FEATURES

AC Power supply ⁽¹⁷⁾		
CVM-E3-MINI-ITF - CVM-E3-MINI-MC - CVM-E3-MINI-FLEX		
Rated voltage	207 ... 253 V ~	100 ... 240 V ~ ± 10%
Frequency	50 ... 60 Hz	50 ... 60 Hz
Consumption	4 VA	4.9 ... 6.1 VA
Installation category	CAT III 300 V	CAT III 300 V
CVM-E3-MINI-ITF-WiEth - CVM-E3-MINI-MC-WiEth - CVM-E3-MINI-FLEX-WiEth		
Rated voltage	100 ... 240 V ~ ± 10%	
Frequency	50 ... 60 Hz	
Consumption	4 ... 5.2 VA	
Installation category	CAT III 300 V	
DC Power supply ⁽¹⁷⁾		
CVM-E3-MINI-ITF - CVM-E3-MINI-MC - CVM-E3-MINI-FLEX		
Rated voltage	100 ... 240 V === ± 10%	
Consumption	3 ... 3.5 W	
Installation category	CAT III 300 V	
CVM-E3-MINI-ITF-WiEth - CVM-E3-MINI-MC-WiEth - CVM-E3-MINI-FLEX-WiEth		
Rated voltage	100 ... 240 V === ± 10%	
Consumption	2.5 ... 2.8 W	
Installation category	CAT III 300 V	

⁽¹⁷⁾ Depending on model.

Voltage measurement circuit	
Rated voltage (Un)	300 V Ph-N, 520 V Ph-Ph
Voltage measurement margin	5 ... 120% Un
Frequency measurement margin	45 ... 65Hz
Input impedance	400 kΩ
Min. voltage measurement (Vstart)	11 V Ph-N
Installation category	CAT III 300 V

Current measurement circuit		
CVM-E3-MINI-FLEX-xxx	Measure through Rogowsky sensors	
Nominal current (In)	CVM-E3-MINI-ITF-xxx	.../5A or .../1 A
	CVM-E3-MINI-MC-xxx	.../0.250 A
	CVM-E3-MINI-FLEX-xxx	2000 A
Current measurement margin	CVM-E3-MINI-ITF-xxx	2 ... 120% In
	CVM-E3-MINI-MC-xxx	2 ... 100% In
	CVM-E3-MINI-FLEX-xxx	2 ... 120% In
Min. current measurement (Istart)	CVM-E3-MINI-ITF-xxx	0.2% In
	CVM-E3-MINI-MC-xxx	0.2% In
	CVM-E3-MINI-FLEX-xxx	5 A
Consumption	0.9 VA	
Installation category	CAT III 300 V	

Measurement accuracy			
Voltage measurement	CVM-E3-MINI-ITF-xxx	0.5% ± 1 digit	
	CVM-E3-MINI-MC-xxx		
	CVM-E3-MINI-FLEX-xxx ⁽¹⁸⁾		
Current measurement	CVM-E3-MINI-ITF-xxx	0.5% ± 1 digit	
	CVM-E3-MINI-MC-xxx	0.5% ± 1 digit (10% ≤ I ≤ 100% I _n)	
	CVM-E3-MINI-FLEX-xxx ⁽¹⁸⁾	0.5% ± 1 digit	
Frequency measurement	CVM-E3-MINI-ITF-xxx	0.5%	
	CVM-E3-MINI-MC-xxx		
	CVM-E3-MINI-FLEX-xxx ⁽¹⁸⁾		
Active power measurement	CVM-E3-MINI-ITF-xxx	0.5% ± 2 digits	
	CVM-E3-MINI-MC-xxx	1% ± 2 digits (I > 2%, I ≤ 100% I _n)	
	CVM-E3-MINI-FLEX-xxx ⁽¹⁸⁾	2% ± 2 digits	
Reactive power measurement	CVM-E3-MINI-ITF-xxx	1% ± 2 digits	
	CVM-E3-MINI-MC-xxx	2% ± 2 digits (I ≤ 100% I _n)	
	CVM-E3-MINI-FLEX-xxx ⁽¹⁸⁾	2% ± 2 digits (a 50 Hz) 3% ± 2 digits (a 60 Hz)	
Apparent power measurement	CVM-E3-MINI-ITF-xxx	0.5% ± 2 digits	
	CVM-E3-MINI-MC-xxx	1% ± 2 digits (I > 2%, I ≤ 100% I _n)	
	CVM-E3-MINI-FLEX-xxx ⁽¹⁸⁾	2% ± 2 digits	
Active energy measurement	CVM-E3-MINI-ITF-xxx	I < 0.1I _n	I > 0.1I _n
		Class 1	Class 0.5 (.../1 A) Class 0.5 s (.../5 A)
	CVM-E3-MINI-MC-xxx	Class 1 (I > 2%, I ≤ 100% I _n)	
CVM-E3-MINI-FLEX-xxx ⁽¹⁸⁾	Class 2		
Reactive energy measurement	CVM-E3-MINI-ITF-xxx	Class 2	
	CVM-E3-MINI-MC-xxx	Class 2 (I > 2%, I ≤ 100% I _n)	
	CVM-E3-MINI-FLEX-xxx ⁽¹⁸⁾	Class 3	

⁽¹⁸⁾ Measurement accuracy with sensor.

Pulse outputs (CVM-E3-MINI-ITF, CVM-E3-MINI-MC, CVM-E3-MINI-FLEX)	
Quantity	1
Type	NPN output
Maximum voltage	24 V ===
Maximum current	50 mA
Maximum frequency	16 impulses / sec
Pulse width	30 ms to 500 ms (Programmable)

Digital inputs (CVM-E3-MINI-ITF, CVM-E3-MINI-MC, CVM-E3-MINI-FLEX)	
Quantity	1
Type	NPN Potential free contact
Insulation	optoisolated

Communications (CVM-E3-MINI-ITF, CVM-E3-MINI-MC, CVM-E3-MINI-FLEX)		
	Modbus RTU	BACnet
Bus	RS-485	MS/TP
Protocol	Modbus RTU	BACnet
Baud rate	9600 - 19200 - 38400 ⁽¹⁹⁾ - 57600 ⁽¹⁹⁾ - 115200 ⁽¹⁹⁾ bps	
Stop bits	1 - 2	1

(continuation) Communications (CVM-E3-MINI-ITF, CVM-E3-MINI-MC, CVM-E3-MINI-FLEX)		
	Modbus RTU	BACnet
Parity	without - even - odd	without

⁽¹⁹⁾ Available on devices with software version v2.xx.

Ethernet communications (CVM-E3-MINI-ITF-WiEth, CVM-E3-MINI-MC-WiEth, CVM-E3-MINI-FLEX-WiEth)	
Type	Ethernet 10BaseT - 100BaseTX self-detectable
Connector	RJ45
Protocol	Modbus TCP - Web server
Connection mode to Network	DHCP ON/OFF (ON by default)

Wi-Fi communications (CVM-E3-MINI-ITF-WiEth, CVM-E3-MINI-MC-WiEth, CVM-E3-MINI-FLEX-WiEth)	
Band	2.4 GHz (Range: 2.4 ... 2.5 GHz)
Standard	IEEE 802.11 b / g, IEEE 802.11 n (up to 150 Mbps)
Max. output power	IEEE 802.11 b : 20 dBm IEEE 802.11 n : 14 dBm

Bluetooth® communications (CVM-E3-MINI-ITF-WiEth, CVM-E3-MINI-MC-WiEth, CVM-E3-MINI-FLEX-WiEth)	
Protocols	Bluetooth® v4.2 BR/EDR and BLE specification
Radio	NZIF receiver with -97 dBm sensitivity Class-1, class-2 and class-3 transmitter Adaptive Frequency Hopping (AFH)

User interface	
Display	LCD Custom COG high contrast
Keyboard	Capacitive, 3 keys
LED	2 LED

Environmental features		
Operating temperature	CVM-E3-MINI-xxx	-5°C... +45°C
	CVM-E3-MINI-xxx-WiEth	-10°C... +50°C
Storage temperature	CVM-E3-MINI-xxx	-10°C ... +50°C
	CVM-E3-MINI-xxx-WiEth	-30°C ... +80°C
Relative humidity (non-condensing)	5 ... 95%	
Maximum altitude	2000 m	
Protection degree	IP30, Front: IP40	
Use	Indoor	

Mechanical features		
Dimensions (Figure 39)	52.5 x 118 x 74 mm	
Weight	CVM-E3-MINI-xxx	300 g.
	CVM-E3-MINI-ITF-WiEth	275 g.
	CVM-E3-MINI-MC-WiEth	255 g.
	CVM-E3-MINI-FLEX-WiEth	255 g.
Surround	Self-extinguishing V0 plastic	
Attachment ⁽²⁰⁾	DIN rail	

⁽²⁰⁾ The minimum recommended distance between rails for installing the CVM-E3-MINI device is 150 mm.

Standards	
Safety requirements for electrical equipment for measurement, control and laboratory use -- Part 1: General requirements	EN 61010-1: 2010
Safety requirements for electrical equipment for measurement, control and laboratory use -- Part 2-030: Particular requirements for testing and measuring circuits	EN 61010-2-030: 2010
Electrical equipment for measurement, control and laboratory use - EMC requirements - Part 1: General requirements (Endorsed by AENOR in March of 2013.)	EN 61326-1:2013
Test for flammability of plastic materials for parts in devices and appliances	UL 94
Electrical safety in low voltage distribution systems up to 1 000 V a.c. and 1 500 V d.c. - Equipment for testing, measuring or monitoring of protective measures -- Part 12: Performance measuring and monitoring devices (PMD)	EN 61557-12:2008

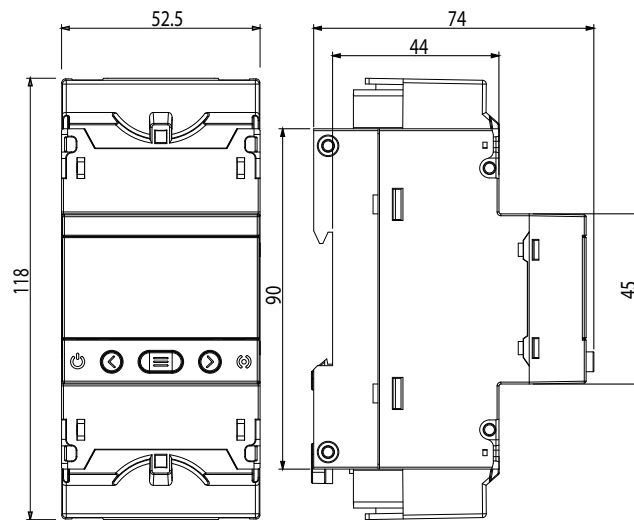

Figure 39: Dimensions of the CVM-E3-MINI.

10.- MAINTENANCE AND TECHNICAL SERVICE

In the case of any query in relation to device operation or malfunction, please contact the **CIRCUTOR S.A.U.** Technical Support Service.

Technical Assistance Service

Vial Sant Jordi, s/n, 08232 - Viladecavalls (Barcelona)

Tel: 902 449 459 (Spain) / +34 937 452 919 (outside of Spain)

email: sat@circutor.com

11.- GUARANTEE

CIRCUTOR guarantees its products against any manufacturing defect for two years after the delivery of the units.

CIRCUTOR will repair or replace any defective factory product returned during the guarantee period.



- No returns will be accepted and no unit will be repaired or replaced if it is not accompanied by a report indicating the defect detected or the reason for the return.
- The guarantee will be void if the units has been improperly used or the storage, installation and maintenance instructions listed in this manual have not been followed. "Improper usage" is defined as any operating or storage condition contrary to the national electrical code or that surpasses the limits indicated in the technical and environmental features of this manual.
- **CIRCUTOR** accepts no liability due to the possible damage to the unit or other parts of the installation, nor will it cover any possible sanctions derived from a possible failure, improper installation or "improper usage" of the unit. Consequently, this guarantee does not apply to failures occurring in the following cases:
 - Overvoltages and/or electrical disturbances in the supply;
 - Water, if the product does not have the appropriate IP classification;
 - Poor ventilation and/or excessive temperatures;
 - Improper installation and/or lack of maintenance;
 - Buyer repairs or modifications without the manufacturer's authorisation.

12.- EU DECLARATION OF CONFORMITY



CIRCUTOR, SA – Vial Sant Jordi, s/n
08232 Viladecavalls (Barcelona) Spain
(+34) 937 452 900 – info@circutor.com



DECLARACIÓN UE DE CONFORMIDAD

La presente declaración de conformidad se expide bajo la exclusiva responsabilidad de CIRCUTOR con dirección en Vial Sant Jordi, s/n – 08232 Viladecavalls (Barcelona) España

Producto:

Analizadores de redes trifásicos, carril DIN

Serie:

CVM-E3-MINI

Marca:

CIRCUTOR

El objeto de la declaración es conforme con la legislación de armonización pertinente en la UE, siempre que sea instalado, mantenido y usado en la aplicación para la que ha sido fabricado, de acuerdo con las normas de instalación aplicables y las instrucciones del fabricante

2014/35/UE: Low Voltage Directive 2014/30/UE: Electromagnetic Compatibility Directive
2011/65/UE: RoHS2 Directive

Está en conformidad con la(s) siguiente(s) norma(s) u otro(s) documento(s) normativos(s):

IEC 61010-1:2010+AMD1:2016 CSV Ed.3.0 IEC 61326-1:2012 Ed. 2.0
IEC 61557-12:2007 Ed. 1.0

Año de marcado "CE":

2018



EU DECLARATION OF CONFORMITY

This declaration of conformity is issued under the sole responsibility of CIRCUTOR with registered address at Vial Sant Jordi, s/n – 08232 Viladecavalls (Barcelona) Spain

Product:

Power analyzer, three-phase DIN rail

Series:

CVM-E3-MINI

Brand:

CIRCUTOR

The object of the declaration is in conformity with the relevant EU harmonisation legislation, provided that it is installed, maintained and used for the application for which it was manufactured, in accordance with the applicable installation standards and the manufacturer's instructions

2014/35/UE: Low Voltage Directive 2014/30/UE: Electromagnetic Compatibility Directive
2011/65/UE: RoHS2 Directive

It is in conformity with the following standard(s) or other regulatory document(s):

IEC 61010-1:2010+AMD1:2016 CSV Ed.3.0 IEC 61326-1:2012 Ed. 2.0
IEC 61557-12:2007 Ed. 1.0

Year of CE mark:

2018



DÉCLARATION UE DE CONFORMITÉ

La présente déclaration de conformité est délivrée sous la responsabilité exclusive de CIRCUTOR dont l'adresse postale est Vial Sant Jordi, s/n – 08232 Viladecavalls (Barcelona) Espagne

Produit:

analyseurs de réseaux triphasés, rail DIN

Série:

CVM-E3-MINI

Marque:

CIRCUTOR

L'objet de la déclaration est conforme à la législation d'harmonisation pertinente dans l'UE, à condition d'avoir été installé, entretenu et utilisé dans l'application pour laquelle il a été fabriqué, conformément aux normes d'installation applicables et aux instructions du fabricant

2014/35/UE: Low Voltage Directive 2014/30/UE: Electromagnetic Compatibility Directive
2011/65/UE: RoHS2 Directive

Il est en conformité avec la(les) suivante(s) norme(s) ou autre(s) document(s) réglementaire(s):

IEC 61010-1:2010+AMD1:2016 CSV Ed.3.0 IEC 61326-1:2012 Ed. 2.0
IEC 61557-12:2007 Ed. 1.0

Année de marquage « CE »:

2018



Viladecavalls (Spain), 08/02/2018
General Manager: Ferran Gil Torné



CIRCUTOR, SA – Vial Sant Jordi, s/n
08232 Viladecavalls (Barcelona) Spain
(+34) 937 452 900 – info@circutor.com



KONFORMITÄTSERKÄRUNG UE

Vorliegende Konformitätserklärung wird unter alleiniger Verantwortung von CIRCUTOR mit der Anschrift: Vial Sant Jordi, s/n – 08232 Viladecavalls (Barcelona) Spanien, ausgestellt

Produkt:

Dreiphasen-Leistungsanalyser, DIN-Schiene

Serie:

CVM-E3-MINI

Marke:

CIRCUTOR

Der Gegenstand der Konformitätserklärung ist konform mit der geltenden Gesetzgebung zur Harmonisierung der EU, sofern die Installation, Wartung und Verwendung der Anwendung seinem Verwendungszweck entsprechend gemäß den geltenden Installationsstandards und der Vorgaben des Herstellers erfolgt.

2014/35/UE: Low Voltage Directive 2014/30/UE: Electromagnetic Compatibility Directive
2011/65/UE: RoHS2 Directive

Es besteht Konformität mit der/den folgender/folgenden Norm/Normen oder Regelwerk/Regelwerken

IEC 61010-1:2010+AMD1:2016 CSV Ed 3.0 IEC 61326-1:2012 Ed 2.0
IEC 61557-12:2007 Ed 1.0

Jahr der CE-Kennzeichnung:

2018



DECLARAÇÃO DA UE DE CONFORMIDADE

A presente declaração de conformidade é expedida sob a exclusiva responsabilidade da CIRCUTOR com morada em Vial Sant Jordi, s/n – 08232 Viladecavalls (Barcelona) Espanha

Produto:

Analísadores de redes trifásicos, Calha DIN

Série:

CVM-E3-MINI

Marca:

CIRCUTOR

O objeto da declaração está conforme a legislação de harmonização pertinente na UE, sempre que seja instalado, mantido e utilizado na aplicação para a qual foi fabricado, de acordo com as normas de instalação aplicáveis e as instruções do fabricante.

2014/35/UE: Low Voltage Directive 2014/30/UE: Electromagnetic Compatibility Directive
2011/65/UE: RoHS2 Directive

Está em conformidade com a(s) seguinte(s) norma(s) ou outro(s) documento(s) normativo(s):

IEC 61010-1:2010+AMD1:2016 CSV Ed 3.0 IEC 61326-1:2012 Ed 2.0
IEC 61557-12:2007 Ed 1.0

Ano de marcação "CE":

2018



DICHIARAZIONE DI CONFORMITÀ UE

La presente dichiarazione di conformità viene rilasciata sotto la responsabilità esclusiva di CIRCUTOR, con sede in Vial Sant Jordi, s/n – 08232 Viladecavalls (Barcelona) Spagna

prodotto:

Analizzatori di reti trifase, binario DIN

Serie:

CVM-E3-MINI

MARCHIO:

CIRCUTOR

L'oggetto della dichiarazione è conforme alla pertinente normativa di armonizzazione dell'Unione Europea, a condizione che venga installato, mantenuto e utilizzato nell'ambito dell'applicazione per cui è stato prodotto, secondo le norme di installazione applicabili e le istruzioni del produttore.

2014/35/UE: Low Voltage Directive 2014/30/UE: Electromagnetic Compatibility Directive
2011/65/UE: RoHS2 Directive

È conforme alle seguenti normative o altri documenti normativi:

IEC 61010-1:2010+AMD1:2016 CSV Ed 3.0 IEC 61326-1:2012 Ed 2.0
IEC 61557-12:2007 Ed 1.0

Anno di marcatura "CE":

2018



Viladecavalls (Spain), 08/02/2018
General Manager: Ferran Gil Torné



CIRCUTOR, SA – Vial Sant Jordi, s/n
08232 Viladecavalls (Barcelona) Spain
(+34) 937 452 900 – info@circutor.com



DEKLARACJA ZGODNOŚCI UE

Niniejsza deklaracja zgodności zostaje wydana na wyłączną odpowiedzialność firmy CIRCUTOR z siedzibą pod adresem: Vial Sant Jordi, s/n – 08232 Viladecavalls (Barcelona) Hiszpania

produkt:

Trójfazowe analizatory sieci, szyna DIN

Seria:

CVM-E3-MINI

marka:

CIRCUTOR

Przedmiot deklaracji jest zgodny z odnośnymi wymaganiami prawodawstwa harmonizacyjnego w Unii Europejskiej pod warunkiem, że będzie instalowany, konserwowany i użytkowany zgodnie z przeznaczeniem, dla którego został wyprodukowany, zgodnie z mającymi zastosowanie normami dotyczącymi instalacji oraz instrukcjami producenta

2014/35/UE: Low Voltage Directive 2014/53/UE: Electromagnetic Compatibility Directive
2011/65/UE: RoHS2 Directive

Jest zgodny z następującą(y)mi) normą(ami) lub innym(i) dokumentem(ami) normatywnym(i):

IEC 61010-1:2010+AMD1:2016 CSV Ed 3.0 IEC 61326-1:2012 E d 2.0
IEC 61557-12:2007 Ed 1.0

Rok oznakowania "CE":

2018



Viladecavalls (Spain), 08/02/2018
General Manager: Ferran Gil Torné

ANNEX A.- CONFIGURATION MENUS

Communications Ethernet, Wi-Fi and Bluetooth®

(Models CVM-E3-MINI-xxx-WiEth)

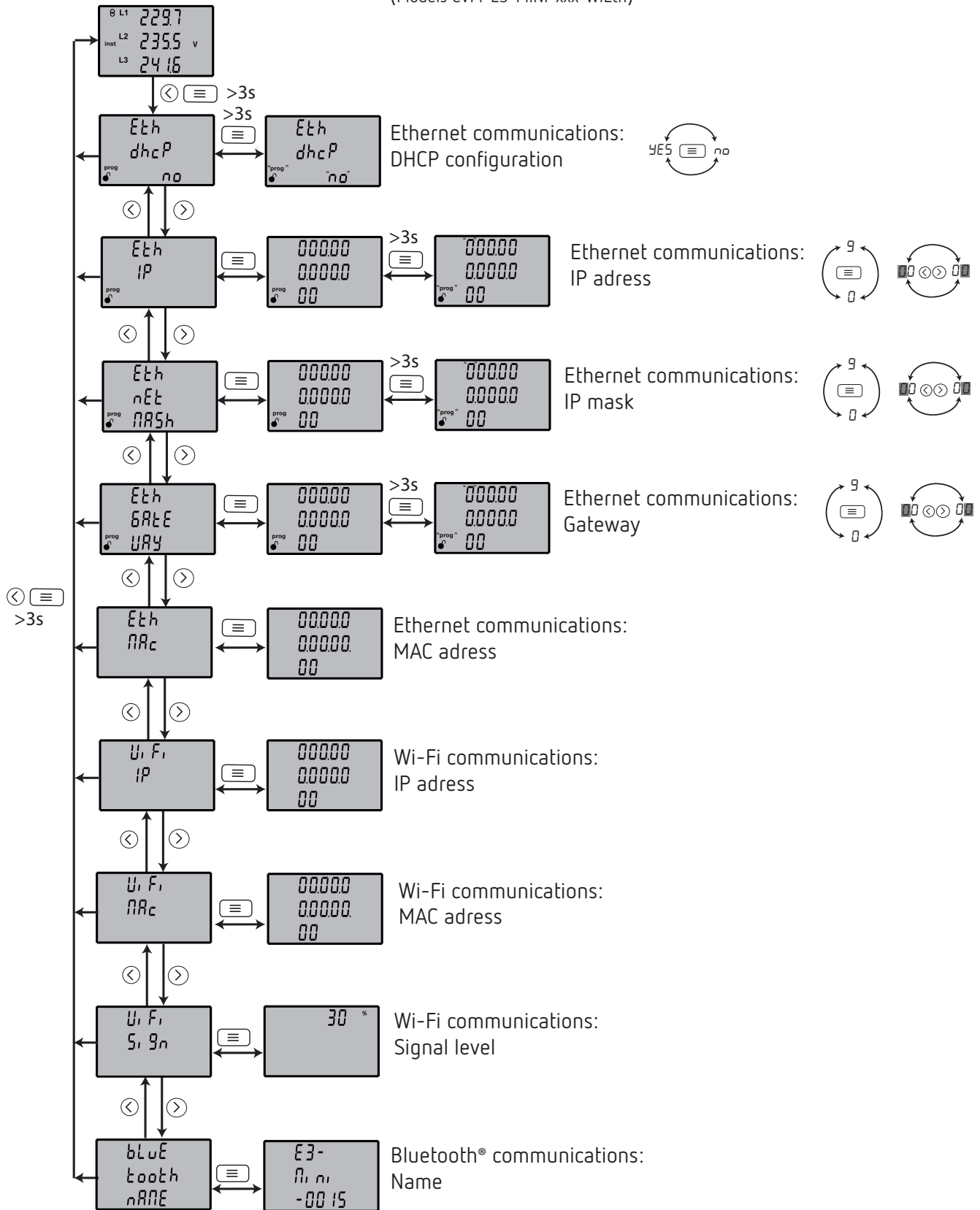

Configuration menu

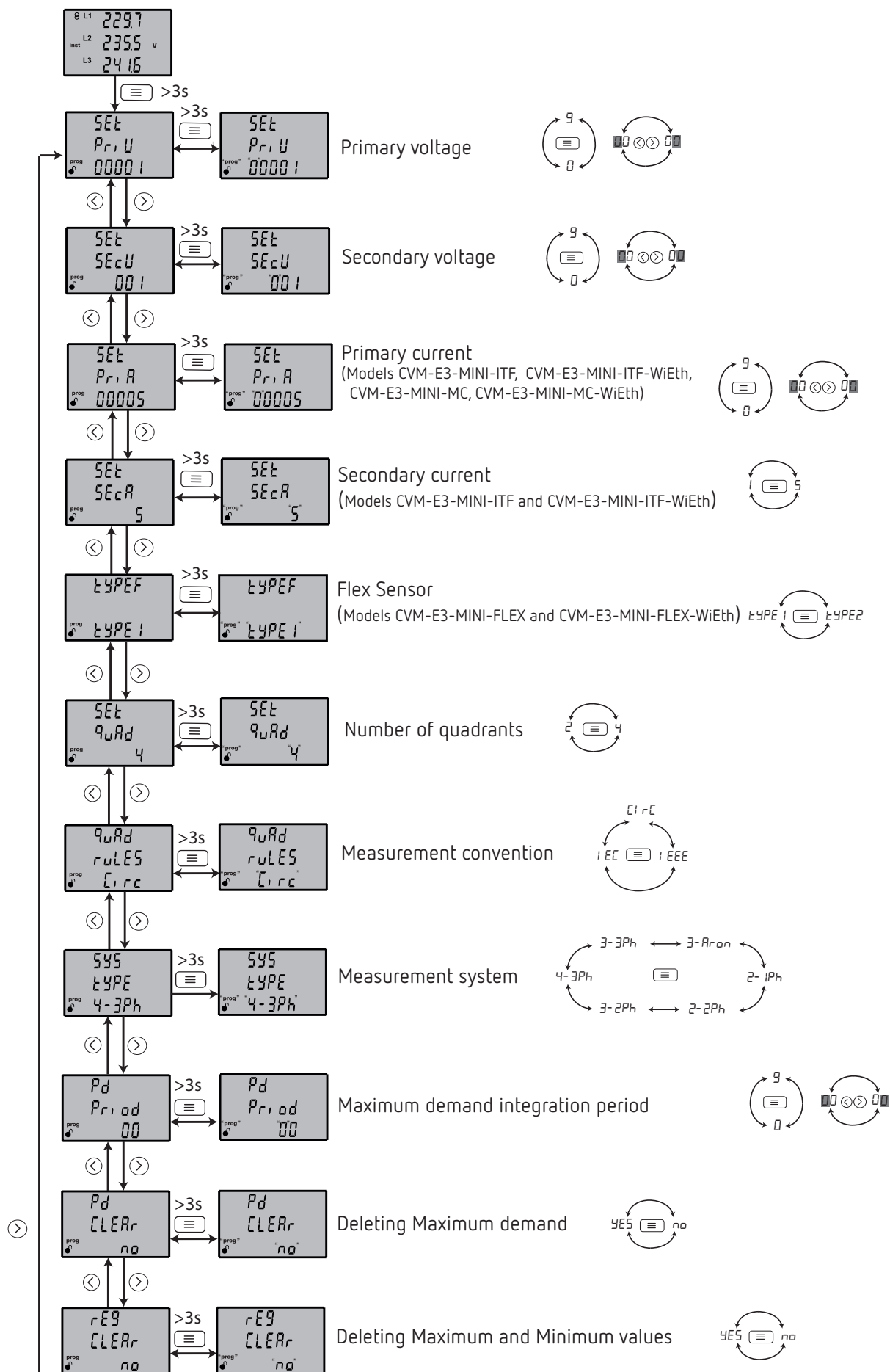

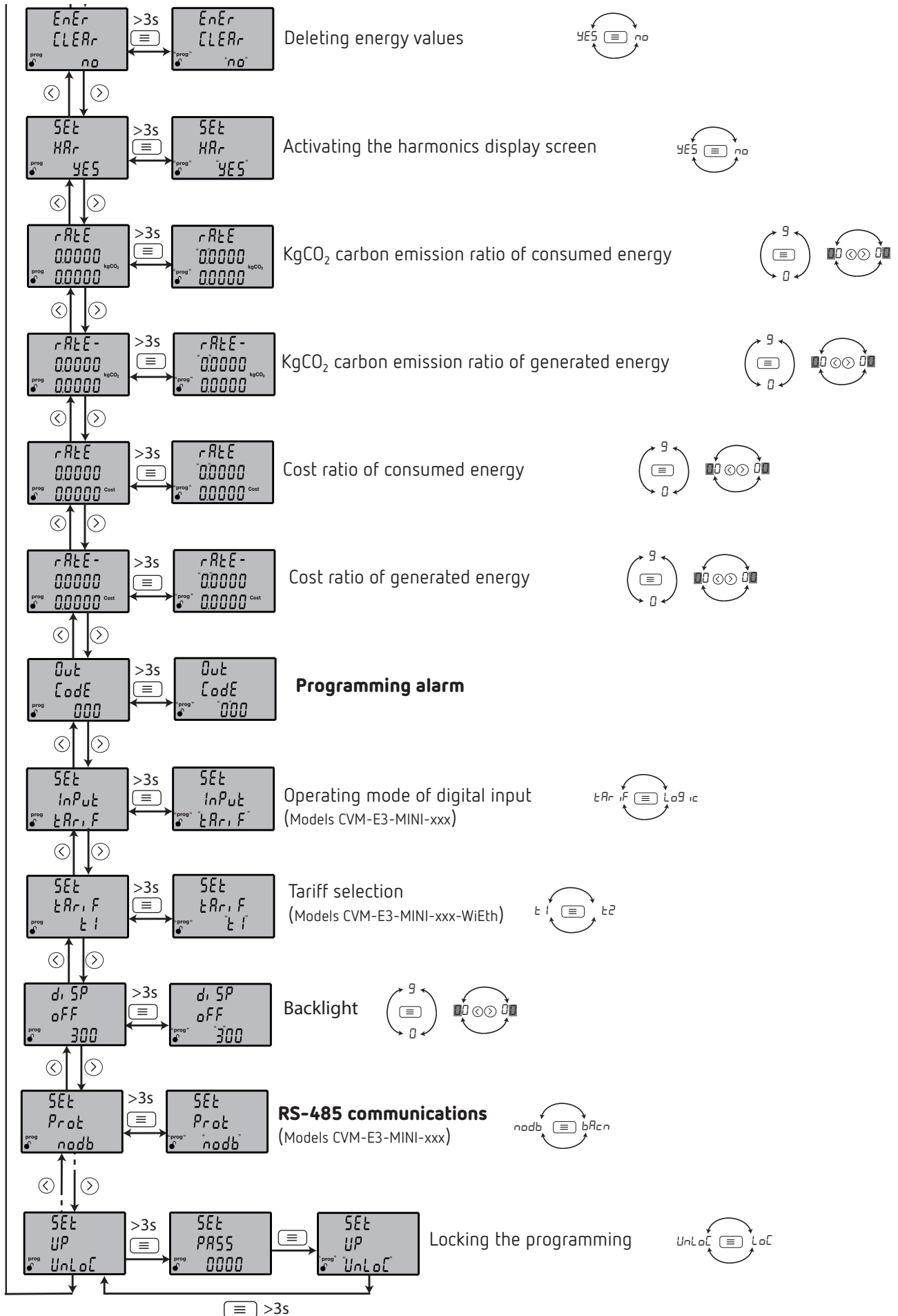

Programming alarm

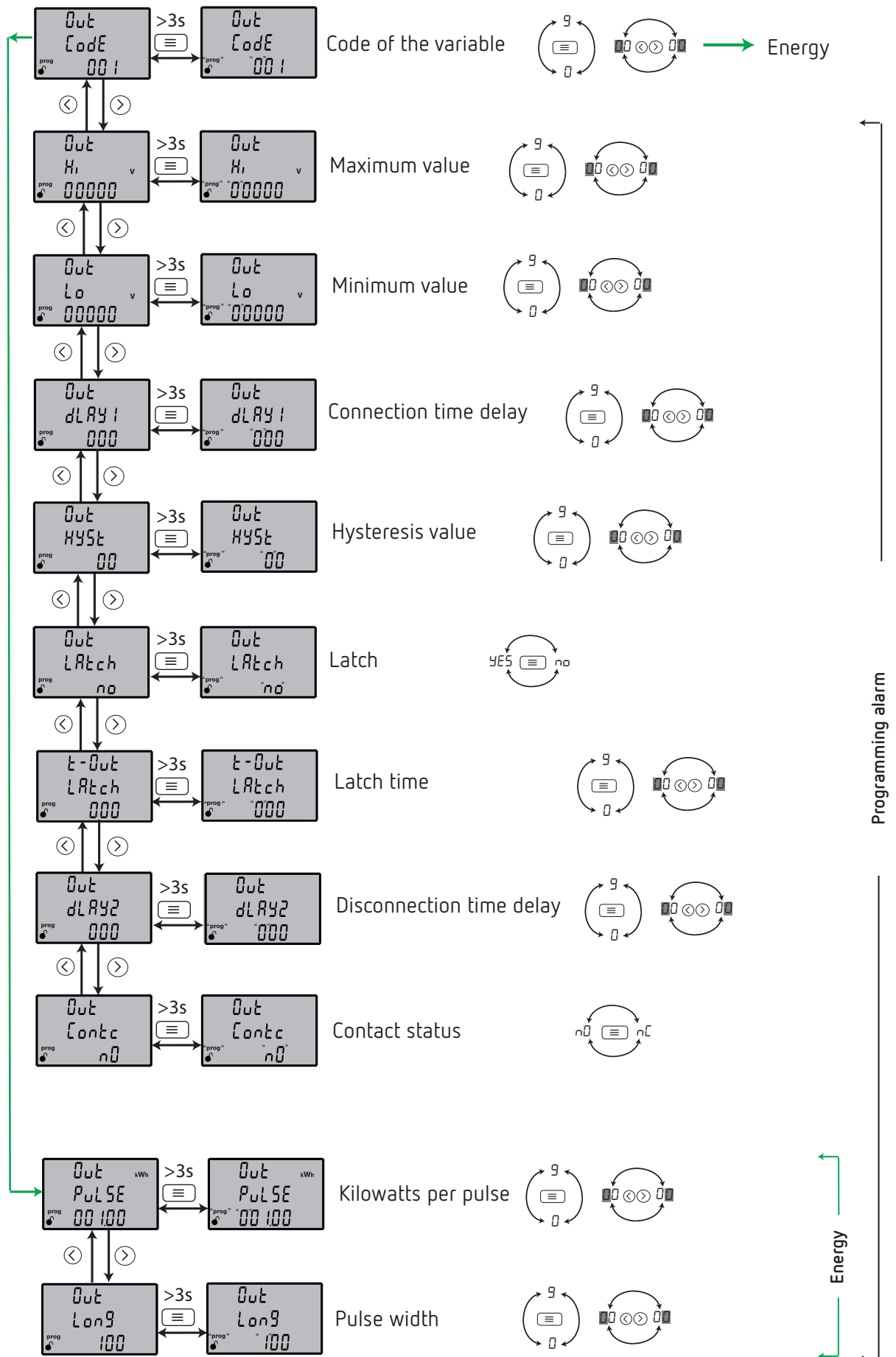

RS-485 communications (Models CVM-E3-MINI-xxx)

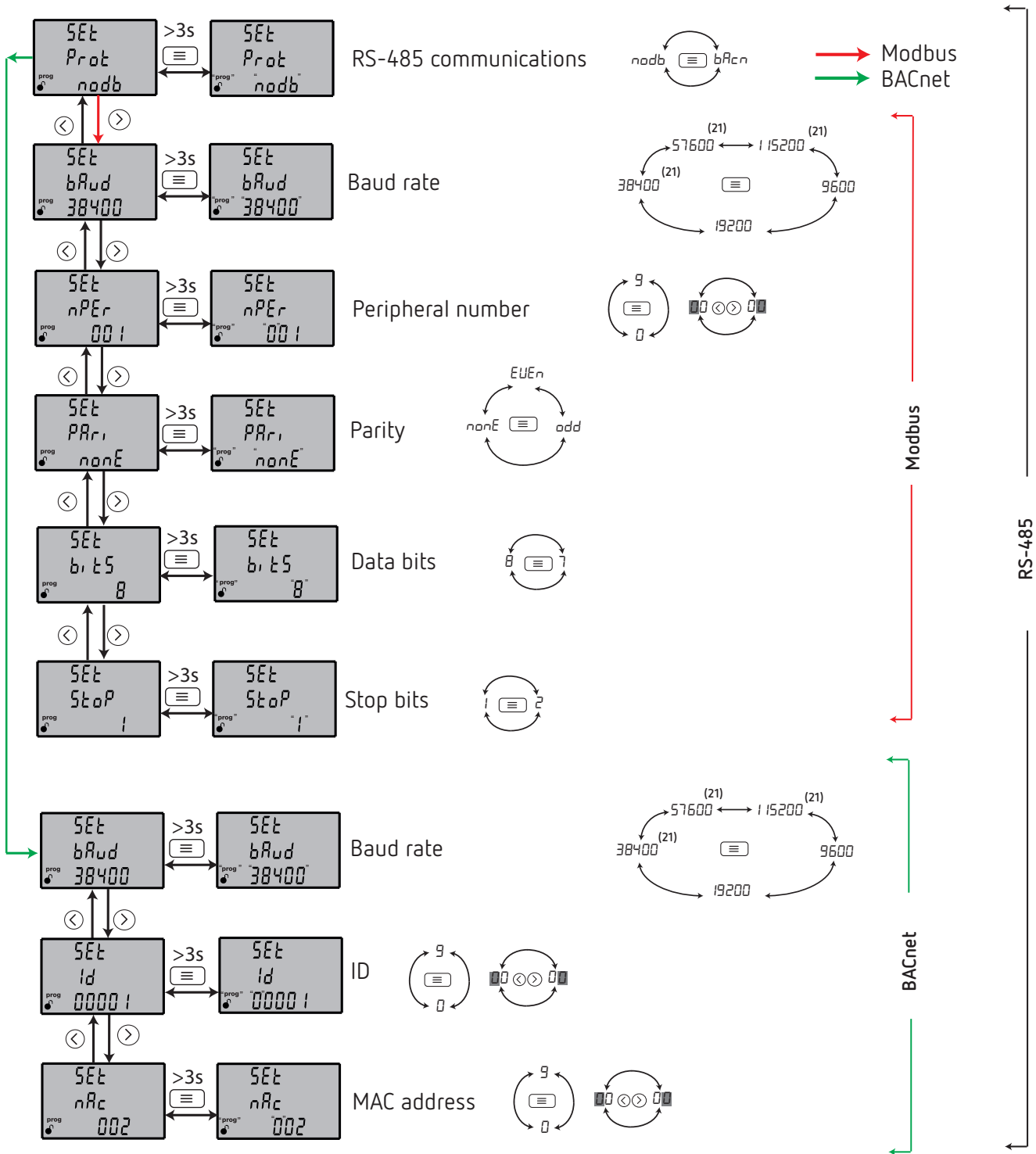

⁽²¹⁾ Available on devices with software version v2.xx.

CIRCUTOR S.A.U.

Vial Sant Jordi, s/n

08232 -Viladecavalls (Barcelona)

Tel.: (+34) 93 745 29 00 - Fax: (+34) 93 745 29 14

www.circutor.com central@circutor.com